

Explosion-proof Fix Camera User Manual



Issue

V1.0

Date

2023-11-15

About This Document

Purpose

Fully understand this document before using this device, and strictly observe rules in this document when using this device. If you install this device in public places, provide the tip "You have entered the area of electronic surveillance" in an eye-catching place. Failure to correctly use electrical products may cause fire and severe injuries. To prevent accidents, carefully read the following context:





Intended Audience

This document is intended for:

- Technical support engineers
- Maintenance engineers
- IP camera operators

Symbols

This document may contain the following symbols whose meanings are described accordingly.

Symbol	Description
 DANGER	It alerts you to fatal dangers which, if not avoided, may cause deaths or severe injuries.
 WARNING	It alerts you to moderate dangers which, if not avoided, may cause minor or moderate injuries.
 CAUTION	It alerts you to risks. Neglect of these risks may cause device damage, data loss, device performance deterioration, or unpredictable results.
 TIP	It provides a tip that may help you resolve problems or save time.
 NOTE	It provides additional information.

Quality Guarantee

For Explosion-proof Fix Camera assemblies, we provide free repair service during the warranty period. The end user is responsible for the cost of labor and component in the follow conditions:

- Damage caused by improper operation that against the Instruction Manual.
- Damage caused by unauthorized disassembly.
- Thunder or other force majeure natural disasters.

If any other contracts between clients and us exist, we will follow the promise or regulation strictly.

Security Assurance

Operation of this product complies with the following requirements:

- No adverse interference in operation;
- The operation of this product cannot be interfered by external factors even adverse interference in a certain degree.

Notice

The user shall not disassemble this product optionally, such as removal of top cover or bolts may cause leakage of water or creepage. Please operate the product according to the requirements in this Instruction Manual;

- Ensure this product is always used in an environment with atmospheric pressure, ambient temperature and relative humidity specified in Chapter 1.6;
- Ensure the power supply complies with the requirement indicated in the nameplate;
- The internal and external grounding shall be reliable;
- Ensure the installation is firm and stable, to avoid unexpected damage of the camera;
- Do not carry out any modification on qualified products, otherwise Explosion-proof performance may be affected.



DANGER

Please read this Instruction Manual carefully before installation and operation of this product.

Please read and understand associate knowledge, safety notices and cautions before put into service.

1. Safety cautions in installation

Cut off the power supply before any maintenance or repair of the product. do not open when energized!

Avoid opening of this product in environment where oil smoke, heavy dust, high temperature or dewing may exist. These will cause the decrease of the image definition.

Connect the cables according to the requirement indicated in the Instruction Manual, otherwise fault may happen.

Protect the flame proof joint in maintenance; avoid any metal fragment or other substances get access in the internal chamber.

No disassembly or modification allowed.

2. Construction Safety

The unit shall be installed in accordance with government regulations and industry standards applicable in that country.

The protective regulations on construction spot shall be followed strictly.

Measurement shall be carried out immediately when any security risks found to eliminate the risks, stop construction if necessary.

All kinds of safety facilities shall be inspected, calibrated or repaired in the event of severe weather.

The ice, fog, rain and snow shall be removed clearly.

Alert area shall be set and a person shall be specified to protect the area when protective casing and other safety facilities are constructed or dismantled.

Work high above the ground may require in installation of this product, the operating personnel shall be qualified.

3. Power supply requirements

Local electrical safety standard shall be followed in the installation and service of this product.

Convenient de-energizing device shall be installed for emergency cutting off.

Verify the output voltage of the power supply before applying power to the unit.

Protect the power cable from trample or compressing, especially for the plug, socket and joint out from devices.

4. Service condition requirements

Please do not focus the camera to hard light (such as lamp or sunlight), which will cause too bright of the image, it's not malfunctions but it does will affect the duration of the CCD (or CMOS).

Transport, operate and store this product in applicable temperature and humidity range. Do not locate it in wet, overheated, extreme cold environment or area with strong electromagnetic radiation or unstable lighting conditions.

The product shall be protected from any entry of water or other conductive fluid, which may damage the internal electrical element.

Avoid overheated, the product shall be well ventilated.

Avoid damage caused by compressing or violent vibration in transmission, storage or operation.

Avoid installing in high vibration areas during storages and deployment.

The product shall be well packaged as new product or equivalent in transmission.

We recommend the installation of lightning surge protection and using this product with Lightning Protection Devices.

Internal and external grounding shall be reliable and the cross-sectional area shall be no less than 4mm².

5. Operation & maintenance requirements

Do not dismantle this product; there is no user serviceable part inside.

Do not touch the CCD (or COMS) directly; a proper way is to blow away the dust with a blower on the lens. If it is necessary to clean it, use soft cloth with a little alcohol to wipe the lens gently. Replace the cover when not use to protect the CCD (or COMS).

Soft, dry cloth can be used for camera window and body cleaning. For hard to clean dirt, neutral detergent can be used, clear the dirt away then dry the camera window and body. Corrosive agents, abrasive cleaners cannot be used for camera window cleaning, they may damage the surface or even decrease the camera performance.

This product shall be installed and repaired by authorized personnel, do not dismantle or attempt repair. Only manufacturer indicated components / accessories can be used when replacement is necessary.

The CCD (or COMS) may be damaged by laser beam, it's better to avoid the camera suffering radiation of laser beam.

6. Environmental protection

For components of the products made by our company that may pollute the environment, such as PCB, electrical elements, plastic and lubricant, collection and control measurement shall be taken in maintenance and scrapping of the products. These pollution sources shall be delivered to the government for further treatment, no casually discard allowed, avoid any adversative effect to the environment.

Special Notes

Pictures in this manual are for reference only.

- We retain the right to modify the content and technical specifications of the product in this Instruction Manual without any form of notification when the product updates, there may exist little differences after updating.
- You can get the latest software and description document by consulting the customer service department.
- Any problem in operation of this product, please contact the distributor or customer service department.
- We always tried to make this instruction manual as perfect as we can, but there still may be some de-tolerance between the real data and the data we provide, if you have any questions or disputes, please refer to our company for finally explanation.

- The operator or user shall be responsible for damages or losses caused by misuse or operations that do not comply with this manual.

Ex Structure instruction

We have made adequate consideration in flameproof enclosure design of the explosion-proof camera to prevent explosive gases getting into the inner volume, the explosion inside the enclosure cannot cause the explosion of the external explosive gases. We ensure the explosion-proof performance by strengthen enclosure the strength, adjust the length and gap of the joint of associate components and limit the maximum surface temperature.

The enclosure can subject to static pressure test (1.5 times of reference pressure at least 10s) specified in EN60079-01/IEC60079-1, no leakage or deformation allowed after test.

The maximum surface temperature will no more than 80°C in normal operation.

Tempering glass is adopted in observation port; the tempering glass shall pass the impact and thermal shock test.

Ingress protection level: IP66,IP68(2m/2h).

Protection the flameproof surface in maintaining of this product, otherwise the damaged flameproof surface will affect the Explosion-proof performance.

When the product needs anti-corrosion treatment, the surface of the product will be sprayed. In this case, please wipe the non-metallic layer with a damp cotton cloth during maintenance. Pay attention to the protective coating. Do not use liquids with strong corrosion.

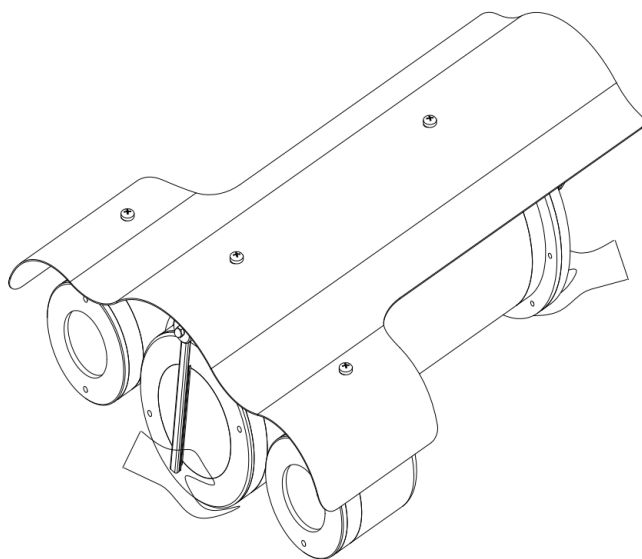
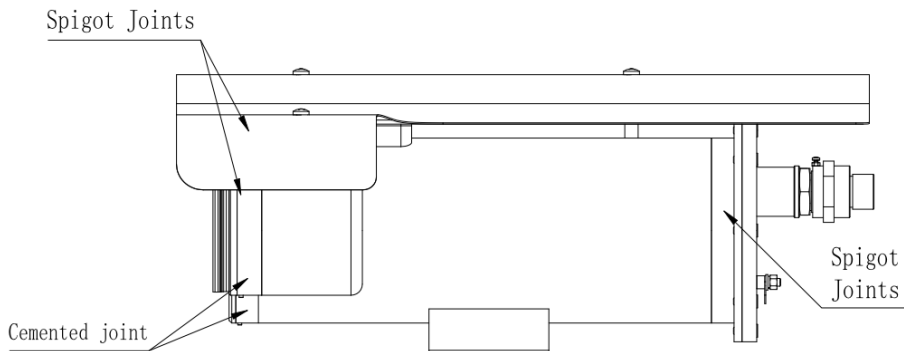

WARNING

How to Move This Product

De-energize the product, and hold the bottom part of the camera to move it, do not place force on the sunshade, wiper, base; do not drag or knock the camera.

When the product is energized: Do not open, move, knock or drag the product.

Special Announcement

All complete products sold by the manufacturer are delivered along with nameplates, operation instructions, and accessories after strict inspection. The manufacturer shall not be held responsible for counterfeit products.

This manual may contain misprints, technology information that is not accurate enough, or product function and operation description that is slightly inconsistent with the actual product. The manufacturer will update this manual according to product function enhancement or changes and regularly update the software and hardware described in this manual. Update information will be added to new versions of this manual without prior notice.

This manual is only for reference and does not ensure that the information is totally consistent with the actual product. For consistency, see the actual product.

Contents

About This Document	i
Contents.....	viii
1 General	1
1.1 Characters	1
1.2 Scope	1
1.3 Dimensions of Explosion-proof Fix Camera	1
1.4 Electrical Parameters	3
1.5 Electrical Safety (in normal atmosphere).....	4
1.6 Special Conditions for Safe Use	4
2 Installation.....	5
2.1 Cautions Before Installation	5
2.2 Cable Entry.....	5
2.3 Preparation of Supports Before Installation.....	5
2.3.1 Support Installation.....	6
2.4 On-spot Installation and Fixing	8
2.4.1 Instruction for Installation	9
2.5 Adjusting and Operation.....	11
2.5.1 System Connection	11
2.5.2 Washing System Connection	12
2.5.3 Cable Specification.....	15
2.5.4 Reset Button	17
2.5.5 SD Card Position	17
2.5.6 Inspection and Examination Before Power on.....	18
2.5.7 Optical Fiber Connector Definition and Fiber Protect Instruction	18
2.5.8 Inspection and Examination Before Power on.....	20
2.5.9 Service Status and Inspection in Service	20
3 Quick Configuration.....	21
3.1 Login and Logout	21
3.2 Change the Password.....	22
3.3 Browse Real-Time Videos	23
3.4 Main Page Layout.....	28

3.5 Playback	31
3.6 People Counting (Only for Some Models)	34
3.6.2 Set Local Network Parameters.....	34
4 PTZ Function Application	38
4.1 PTZ Control function.....	38
4.2 PTZ configuration.....	39
4.2.1 PTZ Setting.....	39
4.2.2 Configure and Apply Preset	40
4.2.3 Configure and Apply Tracks	41
4.2.4 Configure and Apply Scan	42
4.2.5 Configure and Apply Tour	43
4.2.6 Configure and Apply Idle.....	44
4.2.7 Configure Timer.....	45
4.2.8 Configure Extension	46
5 Transportation, storage and maintenance.....	48
5.1 Transportation.....	48
5.2 Storage.....	48
5.3 Maintenance	48
5.4 Trouble-shooting.....	48
A Troubleshooting	50

1 General

1.1 Characters

This camera integrated a variety of communication protocols and speed, it plays an important role in security systems.

This camera can work at wide voltage range and its self-adaptation function will satisfy most brands of the video camera. The surge protection device provided with the camera will make it safer and more reliable

1.2 Scope

This product is applicable for Zone 1 and Zone 2 hazardous areas that explosive mixture of group IIA, IIB, IIC, T1~T6 gases, vapors and air may exists, Zone 21 and Zone 22 hazardous areas that explosive dust may exist.

1.3 Dimensions of Explosion-proof Fix Camera

Dimensions of Explosion-proof Fix Camera is shown in the following figure

Figure 1-1 Camera 1

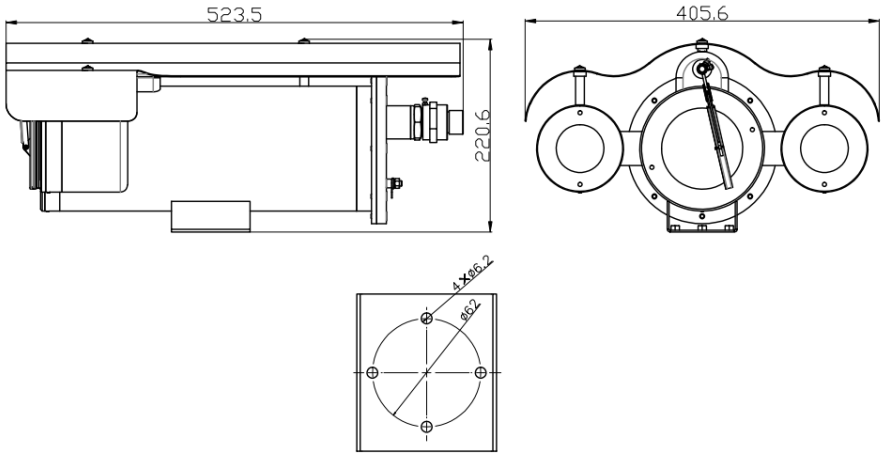

Figure 1-2 Camera 2

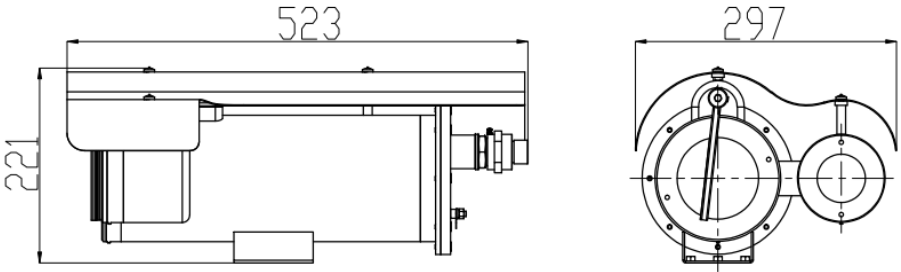
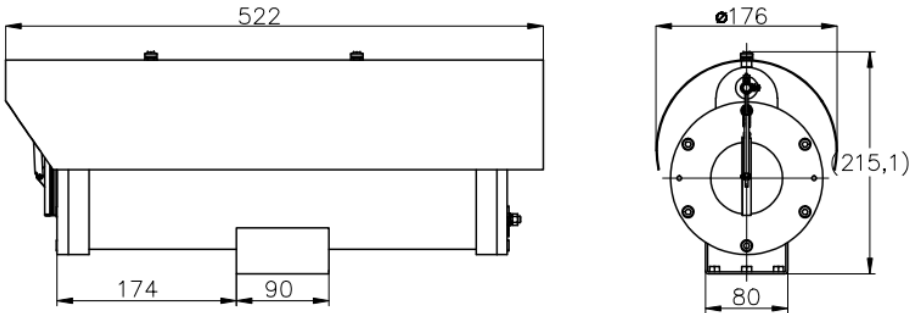

Figure 1-3 Camera 3



1.4 Electrical Parameters

Voltage and Current:	100~240V a.c. or 24V a.c. or 24V d.c. or PoE++(48V d.c.); Max.3A
A.C. Frequency	50/60Hz ±4%
Consumption:	≤50W(excl. the heating fan)
Electrical Connection:	Composite cable
Communication Type	RS-485
Control Communication speed:	2400~19200bps adjustable
Control Communication Protocol:	PELCO-D/PELCO-P
Fast Ethernet Electrical Signal Interface(optional):	full duplex TCP/IP Protocol Ethernet interface transmission
Video Signal (optional):	1-way video output
Audio (optional):	1-way input, 1-way output
Alarm (optional)	2-way alarm input, 1-way alarm output
Washer (optional)	Switch or DC24V or DC12V
Default Button (optional)	2-wire button output(depend on camera)
Address Code:	0/1
Fill-light Distance	100~200M(depend on light Quantity)
Fill-light Type	Double Infrared lights version (8pcs) 4 Near(73.5 degree);4 Far(8 degree); Single infrared light version (4pcs) 2 Near(73.5 degree);2 Far(8 degree)

1.5 Electrical Safety (in normal atmosphere)

Insulation resistance: the insulation resistance between power terminal and the enclosure shall be no less than 50 MΩ;

Dielectric strength: dielectric test of 50Hz, AC1500V shall be conducted between power terminal and the enclosure for 1min; There should be no breakdown or flash-over.

1.6 Special Conditions for Safe Use

- Repairs of the flameproof joints must be made in compliance with the structural specifications provided by the manufacturer. Repairs must not be based on values specified in table 3 and table 4 of IEC/EN60079-1.
- The mechanical property class of the fasteners which are relevant to the flameproof joint should be at least A4-70 with min. Yield stress 450MPa;
- The ambient temperature range is limited to -40°C~+60°C;
- For group III application of fixed installation, the end user shall follow the guidance in the instruction manual to minimize the risk of electrostatic discharge for the products with non-metallic coating.
- For the product, only the composite cable with optical fiber specified in the instruction manual is permitted to be used. Before application, the optical fiber cable must be connected and protected according to the instruction manual to meet the requirements of IEC/EN 60079-28.
- Before application, separate ATEX/IECEx certified Ex db IIC Gb or/and Ex tb IIIC Db IP66/IP68 cable gland should be incorporated.

2 Installation

2.1 Cautions Before Installation

- It's Prohibit customer to disassemble the camera. Otherwise dangerous;
- Check whether it has the explosion proof certificate;
- Check whether it has the explosion proof marking, it should fit the explosion proof environment;
- All explosion-proof parts have no cracks and defects affecting explosion-proof performance;

Cautions in service:

- It's not suggested for users to dismantle this product at will, please follow the Instruction for operation.
- The power must comply with requirements specified in 1.5.
- Please use this product in conditions (atmosphere pressure, temperature and humidity) specified in chapter 1.6.
- Since Ex product is very special, debugging with power before installation if available.
- No extra load on the camera, extra load may cause malfunction or damage!
- Do not open when explosive gas or dust maybe present!

2.2 Cable Entry

There are two cable entries in the rear cover in packaged product, thread spec. is M27×1.25 or M25×1.5. please use with ATEX/IECEX certified cable glands with sealing compound, the Ex marking shall be Ex db IIC Gb/Ex tb IIIC Db IP68 or higher protection level. Follow the instruction of the cable gland for correct installation.

2.3 Preparation of Supports Before Installation

The debugging is done before package, only installation in the intended location is required. We strongly suggest you select supports from our company, it will ease your installation process significantly.

It's the user's responsibility to ensure the support for the camera is strong enough, and the fasteners comply with associate load and anti-rust requirements. Installation of the camera shall ensure that it's out of reach by human beings and there is no other subject may affect the rotation of the camera; otherwise, falling or damage may happen, even personnel safety may be harmed.

2.3.1 Support Installation

Select installation holes in proper positions, the first step is to mount the universal joint with the base of the camera; After that adjust the fasteners of the universal joint based on the area to be monitored to ensure the direction of the camera is correct; At last fasten the support with anchors or plug bolts. Junction box is always installed in positions that easy for installation and maintenance. The cable is connected to junction box by wire casings or bridges.

Specification of the support see Figure 2-1 to Figure 2-4; Universal joint sees Figure 2-5.

Figure 2-1 Installation of support

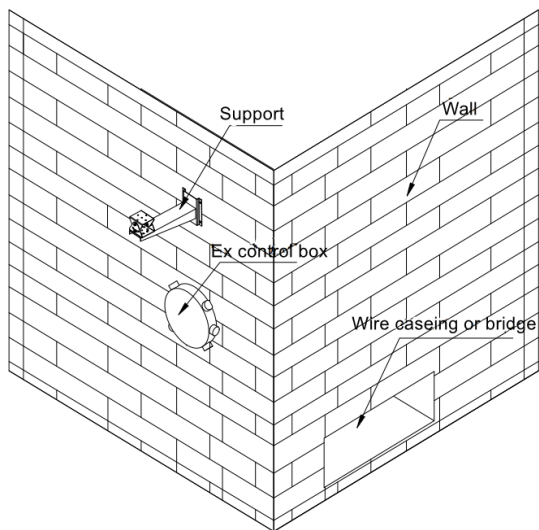

Figure 2-2 Dimension of support

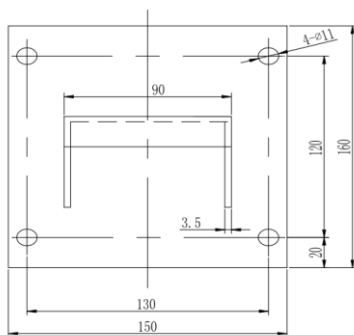

Figure 2-3 Front view of support

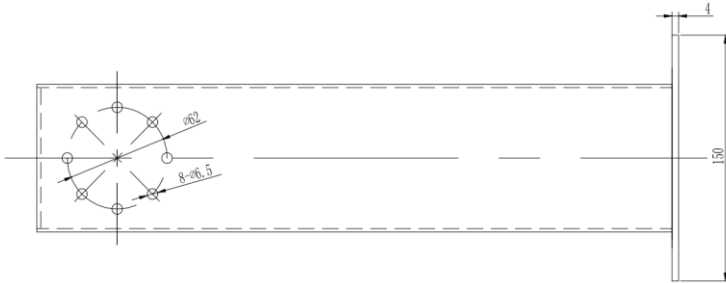

Figure 2-4 Side view of support

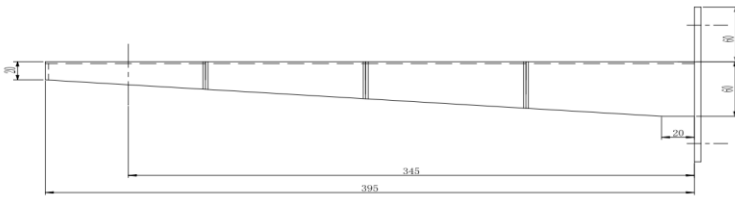
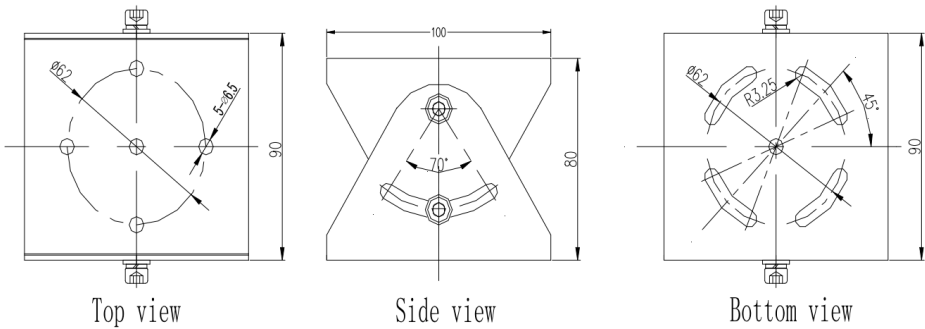

Figure 2-5 Universal joint



2.4 On-spot Installation and Fixing

Since Ex product is very special, adjust with power indoors before installation in the intended locations if available.

2.4.1 Instruction for Installation

See Figure for distribution of installations holes under the camera, take one as example: Pass the reserved cable of the camera through the cable in the support, the cable connected from camera to junction box could be protected by metal pipes; Cable from junction box to control room could be protected by metal pipes or by cable casing, see Figure 2-6.

Figure 2-6 Installation of camera

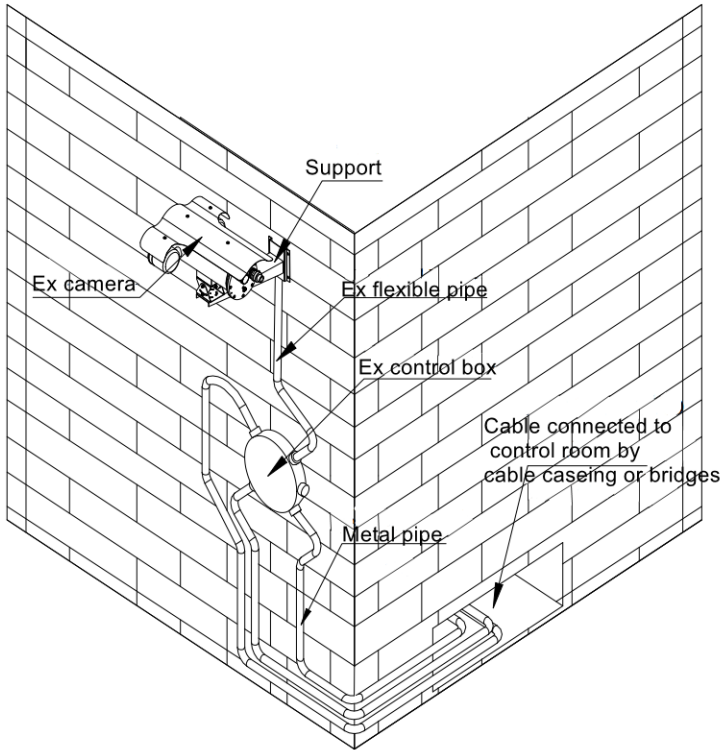

High level connection diagram

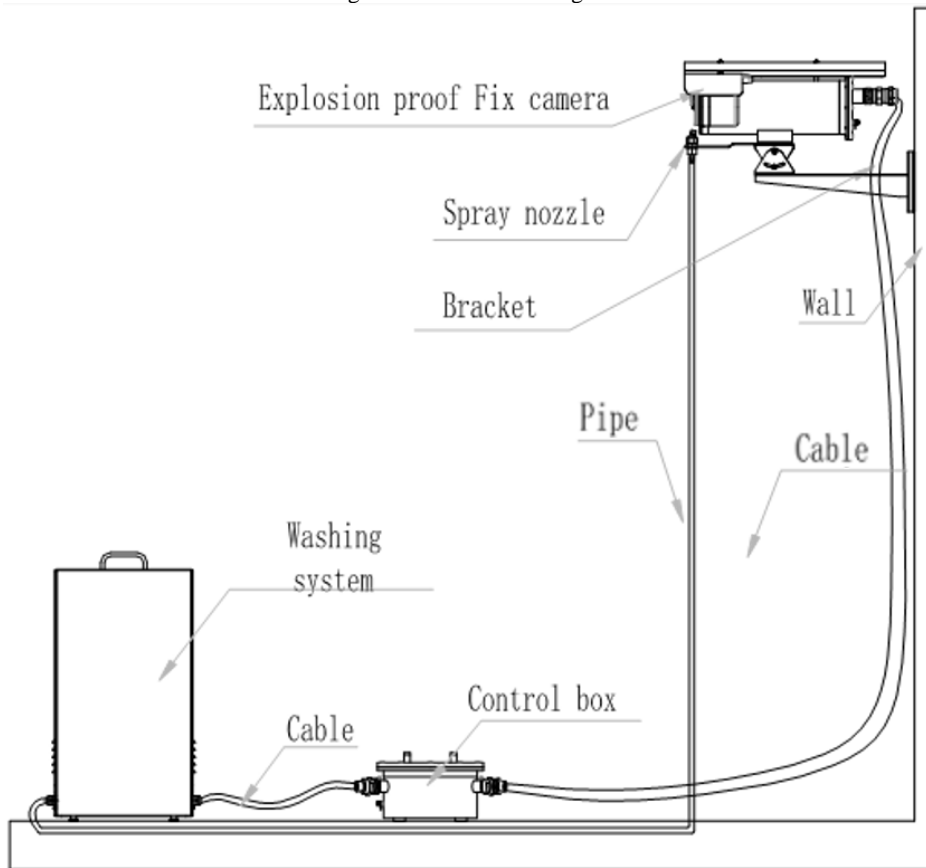

2.5 Adjusting and Operation

2.5.1 System Connection

Figure 2-7 System connection

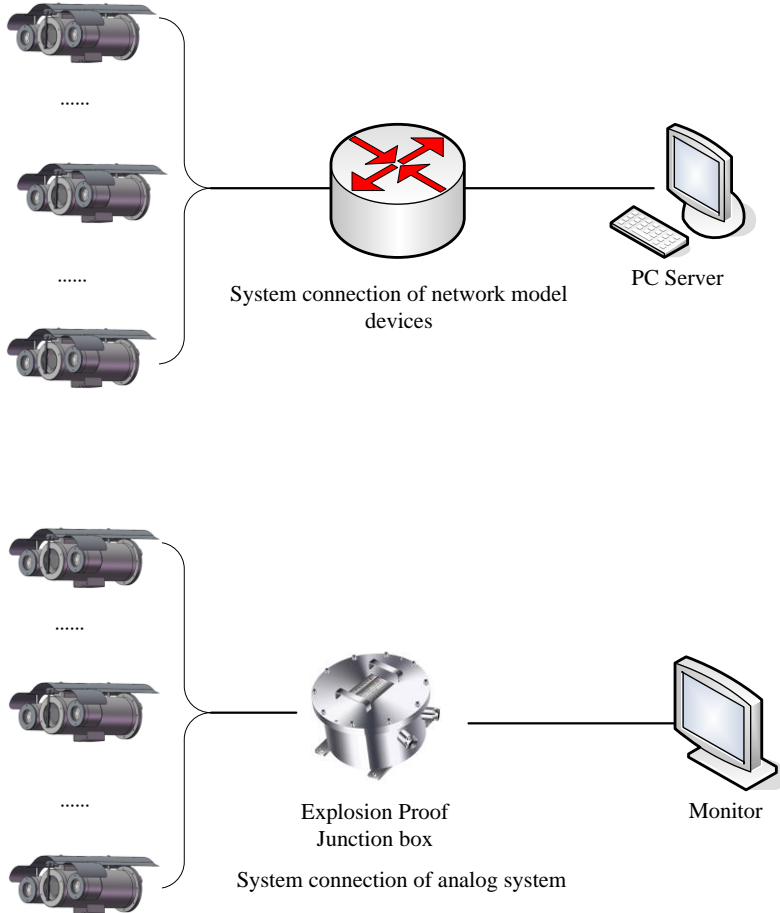

Network model device adopts cable network or wireless network as the main network for digital video signal transmission, it's available for users to monitor or record the videos at any time by network, no matter in local area network (LAN) or wide area network (WAN), such as internet.

Analog system is controlled by Explosion-proof control keyboard and Explosion-proof control box, it's available for user to monitor the scene condition.

2.5.2 Washing System Connection

The connection diagram and wiring definitions of Explosion proof fixed camera, Explosion proof control box and Explosion proof washing system are shown in the following figure.

Figure 2-8 Washing system connection

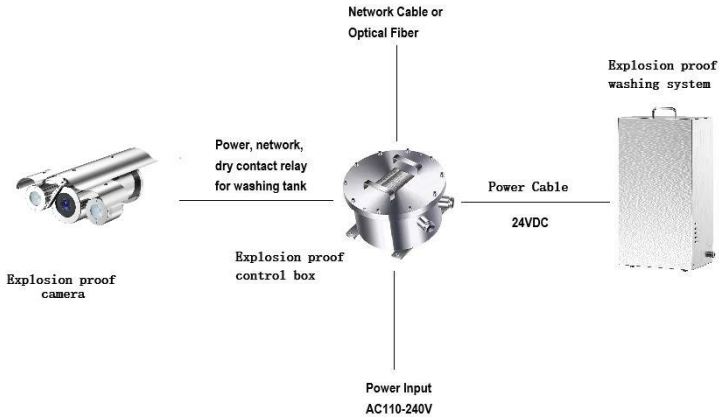

Figure 2-9 Diagram of Explosion proof washing system connection

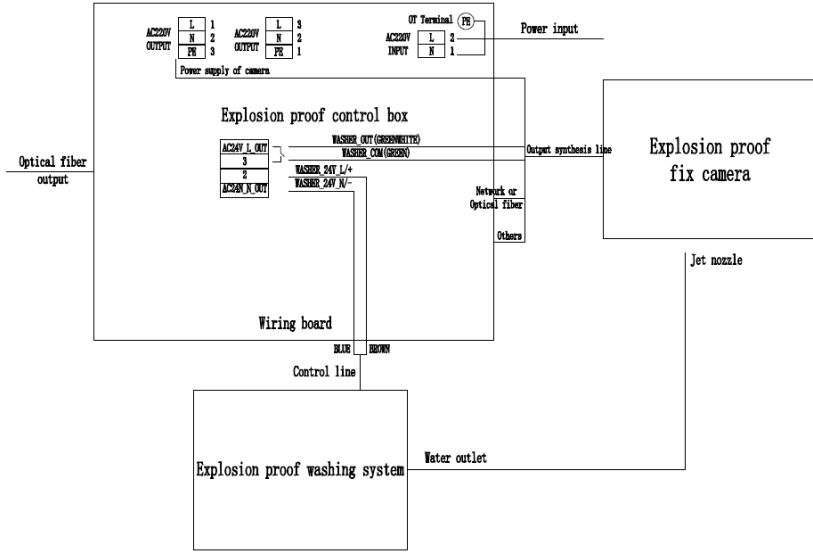
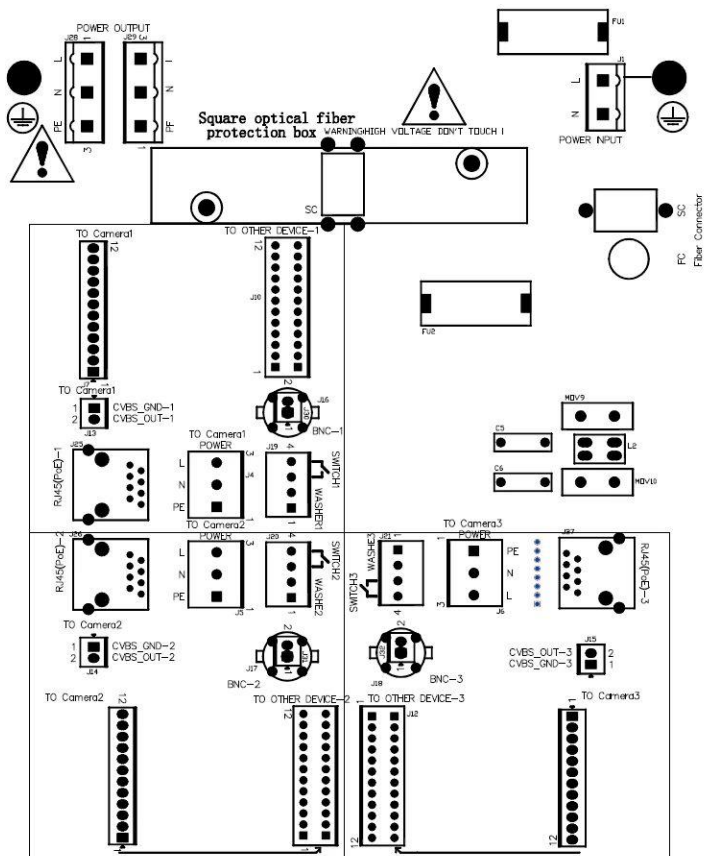

Figure 2-10 Explosion proof control box internal terminal wiring definition figure



Wiring definition for Explosion proof fix camera and Explosion proof control box
(To device1: J7, J13, J19, J25; To device2: J8, J14, J20, J26; To device3: J9, J15, J21, J27):

Part name	Explosion proof fix camera	Explosion proof control box wiring board
Power	AC100-240V	J28 or J29
Network	Fast Ethernet	J25 or J26 or J27
Optical fiber	Single Mode Single Fiber, 1310T/1550R (standard) FC connector	SC/FC

485	485 output A	J7 or J8 or J9 PIN2
	485 output B	J7 or J8 or J9 PIN1
Alarm	Alarm input 1	J7 or J8 or J9 PIN5
	Alarm input 2	J7 or J8 or J9 PIN4
	Alarm input grounding	J7 or J8 or J9 PIN3
	Alarm output 1(COM1)	J7 or J8 or J9 PIN7
	Alarm output 2(OUT1)	J7 or J8 or J9 PIN6
Audio	Audio output	J7 or J8 or J9 PIN8
	Audio grounding	J7 or J8 or J9 PIN9
	Audio input	J7 or J8 or J9 PIN10
Washer	Washer out (COM2)	J19 or J20 or J21 PIN3
	Washer out (OUT2)	J19 or J20 or J21 PIN4
Video	Vo-	J13 or J14 or J15 PIN1
	Vo+	J13 or J14 or J15 PIN2

Wiring definition for Explosion proof control box and Explosion proof washing system:

Explosion proof washing system's control line	Explosion proof control box wiring board's J19 or J20 or J21
Washer_N/(Black 24VDC-)	PIN1
Washer_L/(Red 24VDC+)	PIN2

2.5.3 Cable Specification

A comprehensive cable is provided on packaged product (see Table 2.5.2 for cable specification), the cable is lead out from the side of the base bottom with minimum length of 2m; connect the comprehensive cable to the system bus in the junction box before operation.

Table 2-1 Cable specification

Part name	Color	Function
Audio	purple	Audio output

	black	Audio grounding
	white-purple	Audio input
Alarm	blue-white	Alarm input 1
	blue	Alarm input 2
	black-white	Alarm input grounding
	orange	Alarm output 1(COM1)
	orange-white	Alarm output 2(OUT1)
Reset Button	Red	Default setting
	Gray (non-armored cable)	Default GND
WASHING SWITCH ON/OFF	green	Washer out (COM2)
	green-white	Washer out (OUT2)
RS485 (only for upgrade purpose)	yellow	485 output A
	white	485 output B
VIDEO	Shield	Vo-
	Core	Vo+
Fast Ethernet	orange-white	Network cable 1
	orange	Network cable 2
	green-white	Network cable 3
	blue	Network cable 4
	blue-white	Network cable 5
	green	Network cable 6

	brown-white	Network cable 7
	brown	Network cable 8
Power	thick brown	100-240V AC
	thick yellow-green	grounding
	thick blue	100-240V AC
Optical Fiber	Single Mode Single Fiber, 1310T/1550R (standard) FC connector	

The color of the cable depends on the configuration. The actual tail cable label shall prevail. The above colors are for reference only.

2.5.4 Reset Button

The pigtail cable is coming with the reset button. The reset button consists of two wires (red and gray for non-armored cable) (yellow/White for armored cable) connected to the button.

After holding down the reset button for 60 to 65 seconds, the camera will automatically return to factory setting.

2.5.5 SD Card Position

After open the camera enclosure, you can find the camera module. SD card position as show in the figure below:

Figure 2-11 SD card position

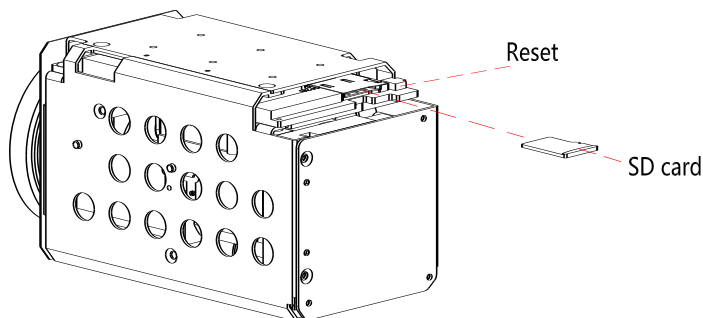

2.5.6 Inspection and Examination Before Power on

Check if the power and network cable are connected correctly, if the toggle switch settings are correct before power on.

2.5.7 Optical Fiber Connector Definition and Fiber Protect Instruction

The camera supports an Ethernet port or optical port connection. The interface adopts encoding and decoding to transmit video signal. It is necessary to choose suitable converter to match the display interface, to convert the interface to Ethernet power port or optical port.

The onboard media converter adapts 100Mbps/1000Mbps Ethernet to single mode single fiber or single mode double fiber. Wave length is 1310nmTx/1550nmRx.

The following specifications of composite cable with optical fiber are recommended. See Table 2-2, Table 2-3, and Figure 2-12.

Table 2-2 Optical fiber parameter

Parameter	Data	Remark
Size	$\Phi 3.0\text{mm}$	
Tensile Strength (N)	Long term:300	
	Short term:500	
Crush Resistance (N/100mm)	Long term:2000	
	Short term:3000	
Min Bending radius(mm)	dynamic:20D	
	Static:10D	
Operating Temp.	-40~+85℃	
Loss (db)	@1310nm $\leq 0.4\text{db/km}$	
	@1550nm $\leq 0.3\text{db/km}$	

Table 2-3 Composite cable with fiber parameter

Name	Colour	O.D.	Conductor Structure
UTP	Black or custom	$0.95 \pm 0.05\text{mm}$	7*0.16mm
Power	Brown blue	$2.80 \pm 0.1\text{mm}$	41*0.16mm

Signal	Black brown red orange Yellow green blue purple Gray white black/white Brown/white red/white orange/white green/white blue/white purple/white	$1.0 \pm 0.05\text{mm}$	$7 \times 0.16\text{mm}$ 17C*26#
Fiber	Blue	$3.0 \pm 0.10\text{mm}$	Armored BIDI SC interface In FC interface OUT
Video	Black	$2.20 \pm 0.08\text{mm}$	$7 \times 0.16\text{mm}$

Figure 2-12 Optical fiber structure diagram

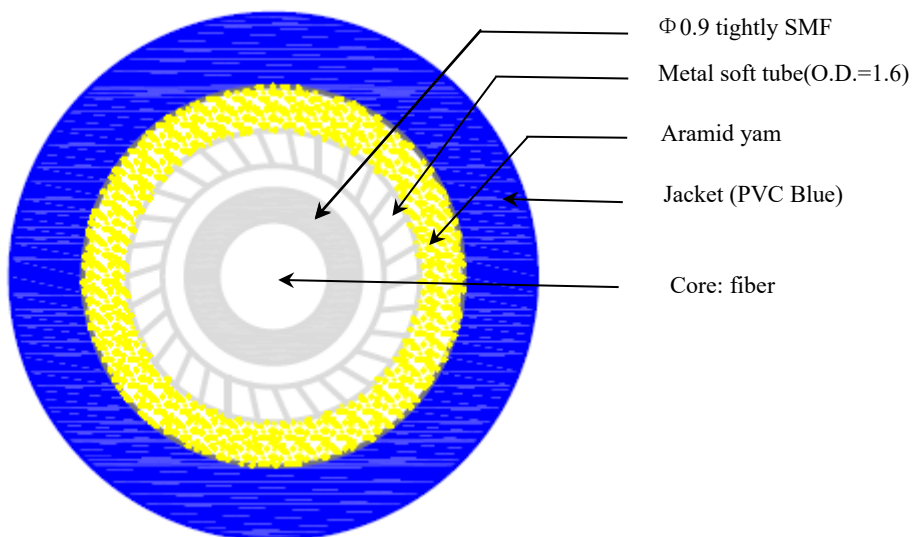

For Optical fiber protection:

In the process of installation and maintenance, please operate according to the requirements of the minimum bending radius of optical fiber, to avoid breaking or increasing the loss of optical fiber.

Be careful not to contaminate the fiber connector.

During the installation, pay attention to fix the suspended optical fiber firmly to avoid damaging the optical fiber during the operation.

It is recommended that users use explosion-proof flexible pipe or galvanized steel pipe to protect the output cable.

Optical fiber connect operation

SC interface is used inside the pigtail cable, as shown in Figure 2-13. The convex part is aligned with the slot of the optical fiber board. Take care not to dirty the interface after removing the protective cover during operation.

Figure 2-13 SC interface structure diagram

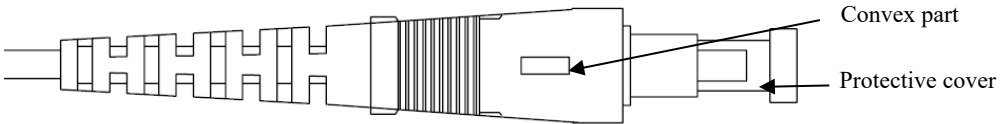

2.5.8 Inspection and Examination Before Power on

Check if the power and network cable are connected correctly, if the toggle switch settings are correct before power on.

2.5.9 Service Status and Inspection in Service

The camera will start self-checking automatically after power on.

3 Quick Configuration

3.1 Login and Logout



CAUTION

To access the web interface through Microsoft Edge, Chrome or Firefox browser; Otherwise some functions may be unavailable.

Login

- Step 1 Open Microsoft Edge, enter the IP address of the IP camera (default value: 192.168.0.120) in the address box, and click on the **Enter** button.

The login page is displayed, as shown in Figure 3-1.

Figure 3-1 Login Page

The screenshot shows the login interface for an IP camera. It features a light blue header with the text 'IP CAMERA' in a large, blue, stylized font. To the right of the header is a language selection dropdown menu currently set to 'English'. Below the header, there are two input fields: 'User Name' containing the text 'admin' and 'Password' containing five black dots. To the right of these fields is a blue button labeled 'Login'.

- Step 2 Enter the user name and password.

The default name and password are both admin. Modify the password when you login the system for first time to ensure system security.

After modifying password, you need to wait at least three minutes then power off to make sure modifying successfully. Or login the Web again to test the new password.

You can change the system display language on the login page.

- Step 3 Click **Login** to enter the interface.

The main page is displayed.

----End

Logout

Click  in the upper right to return to login page.

3.2 Change the Password

Description

For the first login, the page of changing default password is as shown in Figure 3-2.

Figure 3-2 Change the Default Password Page

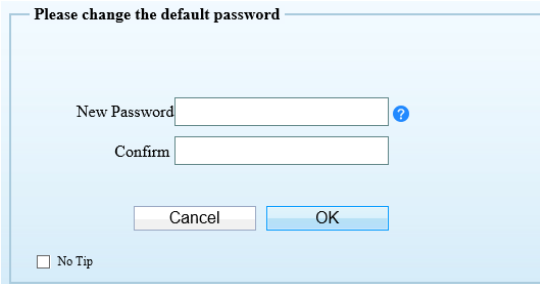

Please change the default password

New Password ?

Confirm

No Tip

Or click  to change the password to login the system, as show in Figure 3-3.

Figure 3-3 Change Password Dialog Box



The image shows a 'Change Password' dialog box with a light blue header and a close button (X) in the top right corner. Below the header is a rounded rectangular area containing three input fields: 'Old Password', 'New Password', and 'Confirm'. Each field has a small '?????' icon on the right side. Below these fields is a section titled 'Password Advice:' followed by three numbered instructions: 1. Advice the password length of eight characters. 2. Advice the password includes numbers, capital letters, lowercase letters and special characters. 3. Advice the password can not be the same as username. At the bottom of the dialog box are two buttons: 'OK' and 'Cancel'.

Procedure

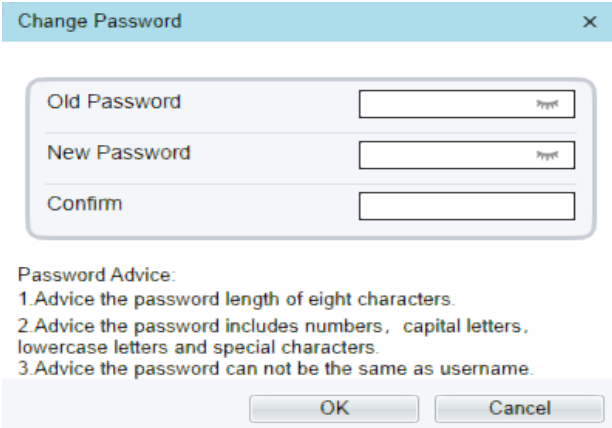
Step 1 Input the old password, new password, and confirmed password.

Step 2 Click **OK**.

If the message "Change own password success" pops up, the password is successfully changed. If the password fails to be changed, the password advice is displayed. (For example, the new password length couldn't be less than eight.)

It is advised to restarted the device three minutes later after modifying password.

Step 3 Click **OK**.

The login page is displayed.

3.3 Browse Real-Time Videos

Download IPC Local Server

If you want to play H.265 encoded video, you should download the latest IPC Local Server, as shown in Figure 3-4, when you login to the web management system for the first time.

Figure 3-4 Download the Plugin Page

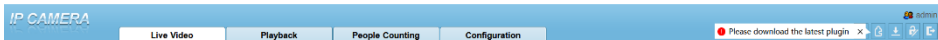

- Step 4 Click “Please download the latest plugin”, download the IPCLocal Server plugin.
- Step 5 Open the download file to complete installation.
- Step 6 Click “Run”, select destination location as shown in Figure 3-5.

Figure 3-5 Select Destination Location

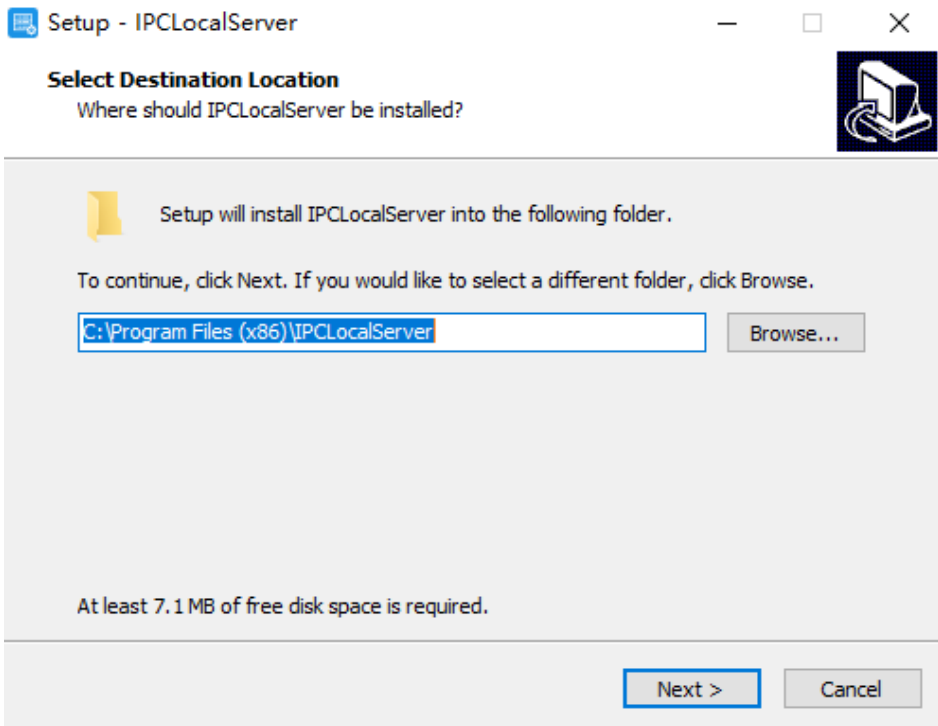

- Step 7 Click “Next”, ready to install the plugin, as shown in Figure 3-6.

Figure 3-6 Select additional tasks

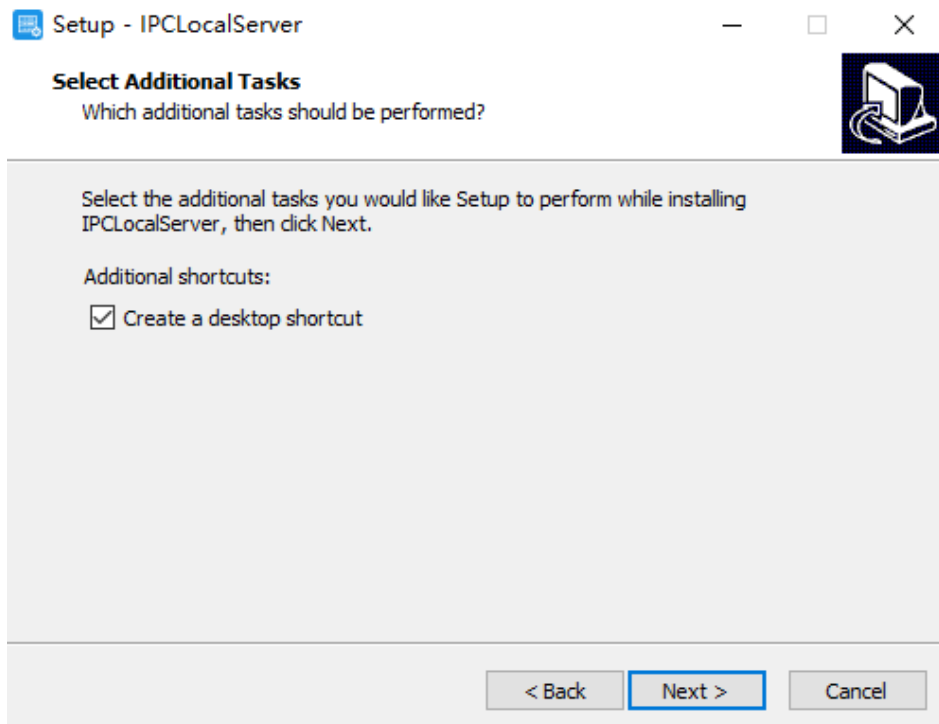

Step 8 Tick “Create a desktop shortcut”, Click “Next” to install the plugin, as shown in Figure 3-7.

Figure 3-7 Installing

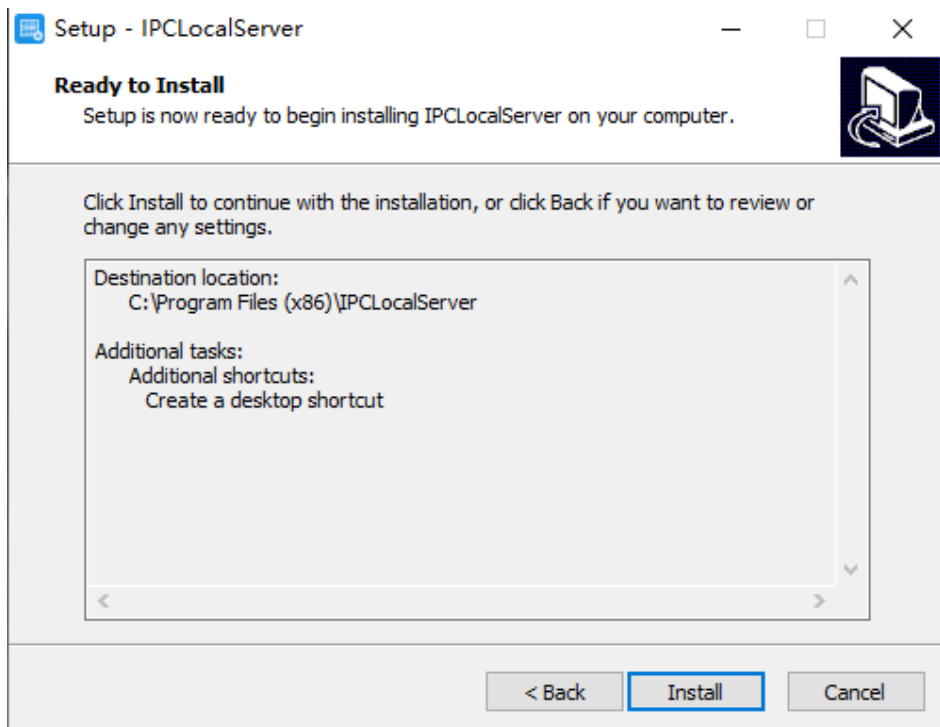

Step 9 Click “Finish”, complete plugin installation, as shown in Figure 3-8.

Figure 3-8 Complete to Install the Plugin

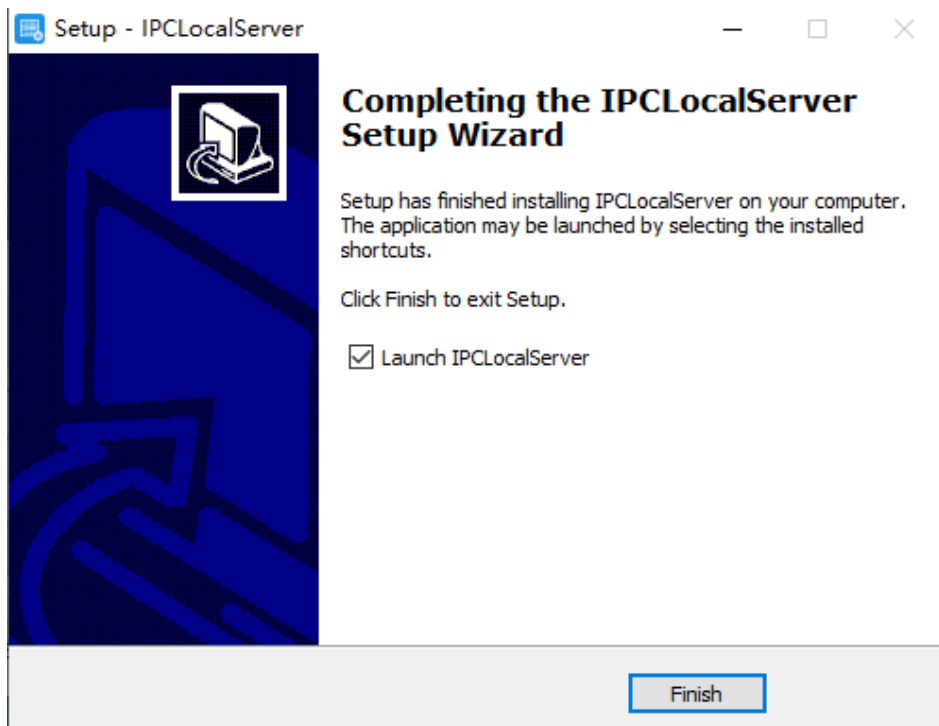

Step 10 Reopen the browser after installing.

 **NOTE**

- If the repair tips displayed when installing the control, please ignore the prompt, and continue the installation.
- During the plugin installing, the browser should be closed.

----End



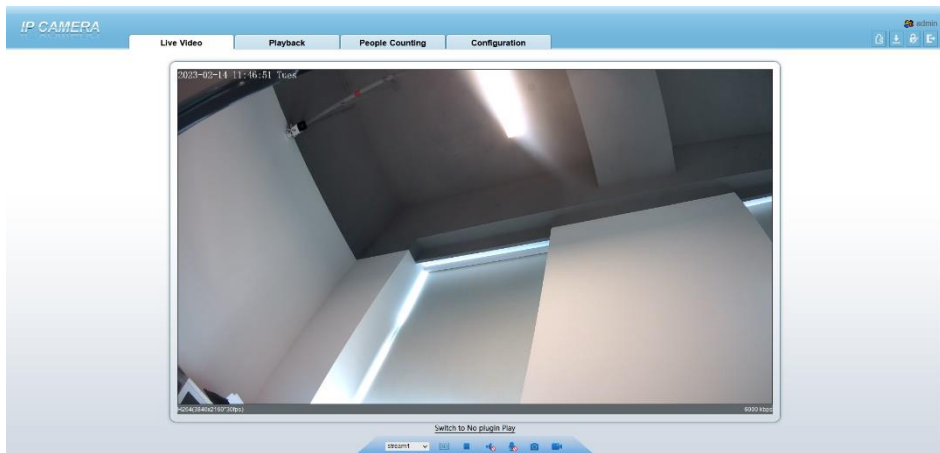

Description

To browse real-time videos, click **Live Video**. The **Live Video** page is displayed, as shown in Figure 3-9.

Figure 3-9 Live Video Page



On the **Live Video** page, you can perform the following operations:

- Click  to stop playing a video.
- Click  to play a video.
- Double-click in the video area to enter the full-screen mode, and double-click again to exit.
- Configure the PTZ. For details, see Table 4-1.
- Control the PTZ. For details, see Table 4-1.
- Switch between three modes. For more details about how to configure streams, see Table 3-1.
- Click  to snapshot and save the photos.
- Click  to enable the local record.

NOTE

- AI interface is supplied for some models.



3.4 Main Page Layout









On the main page, you can view real-time videos, receive alarm and fault notifications, set parameters, change the password, and log out of the system. Figure 3-10 shows the main page layout. Table 3-1 describes the elements on the main page.

Figure 3-10 Main page layout



Table 3-1 Elements on the main page

No.	Element	Description
1	Real-time Video Area	Real-time videos are played in this page.
2	Playback	You can query the playback videos in this area. NOTE Only when the SD card or NAS has videos can you query the playback videos.
3	People Counting	Set the query condition to query the personnel count, the statistical can be shown in different types, such as line chart, histogram, list. Only for Some Models.
4	Device Configuration	You can choose a menu to set device parameters, including the device information, audio and video streams, alarm setting, privacy mask function and so on.
5		When the device accepts an alarm signal, the alarm icon will display within 10s in the web management system. The alarm icon  is displayed. You can click  to view the alarm information.

No.	Element	Description
		<h3>Help of intercom</h3>  <p>Description: Configure only Chrome browser in the HTTP environment, compatible with all browsers in HTTPS environments</p> <p>HTTP Environment Chrome Opens the intercom step:</p> <ol style="list-style-type: none"> 1.Chrome Enter 'chrome://flags#unsafely-treat-insecure-origin-as-secure' in the address bar 2.Set 'INSECURE Origins Treated as Secure' to 'Enabled' 3 Fill in the device domain name in the input box, multiple devices named ',' separation; example http://192.168.0.123, http://192.168.0.123:8045'
		Download the latest plugin IPC Local Server.
		Change password, you can click  to change the password.
		Sign Out, you can click  to return to the login page.
6	PTZ	Only used for dome cameras, set PTZ parameters. Such as zoom in/zoom out, iris +/iris-, focus in / focus out, Preset / Track / Scan / Tour / Idle / Timer / Extension.
7	Switch to No Plugin Play	Support two methods to play live video, plugin play and no plugin play. For no plugin play, the default stream is stream 1.  NOTE Preset 103 Turn on the wipers Preset 116 Turn on the spray
8	Stream	Choose stream mode from drop-list. Set the parameters in " Configuration > Streams > Basic Streams ".
	3D	The 3D positioning function quickly rotates the PTZ and changes the focal length in specific scenarios. You can also change the focus by drawing rectangle frames. Only for Some Models.
	Pause /Play Video	Pause the live video or play the video.
	Audio	Open/close the audio.
	Microphone	Open/close the microphone.
	Snapshot	Click the icon to snapshot the video and save the images to the specified location.
	Local Record	Record the video and save the file to the specified location.
9	AI Interface	Click the icon to switch to AI live video, you can view the snapshots of AI multi object, there are face, plate, car, human body, riding. Only for Some Models.

No.	Element	Description
10	Mode	Only used for fisheye camera, click the icon to choose mode to play video.

Figure 3-11 AI multi object interface

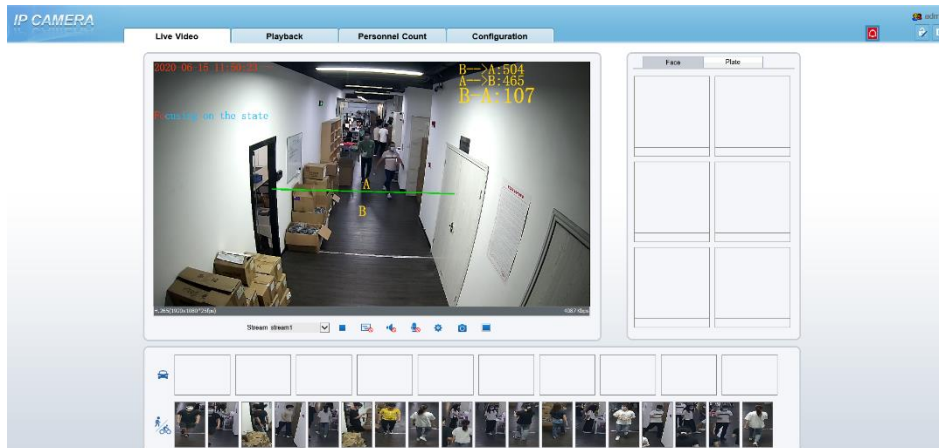

The face frame will show the snapshot of human face.

The plate frame will show the snapshot of license plate.

3.5 Playback

Click “Playback” at web interface, if users install SD card, and there are video in SD card, click “Playback” and the playback video will show as in Figure 3-12.

Figure 3-12 Playback interface

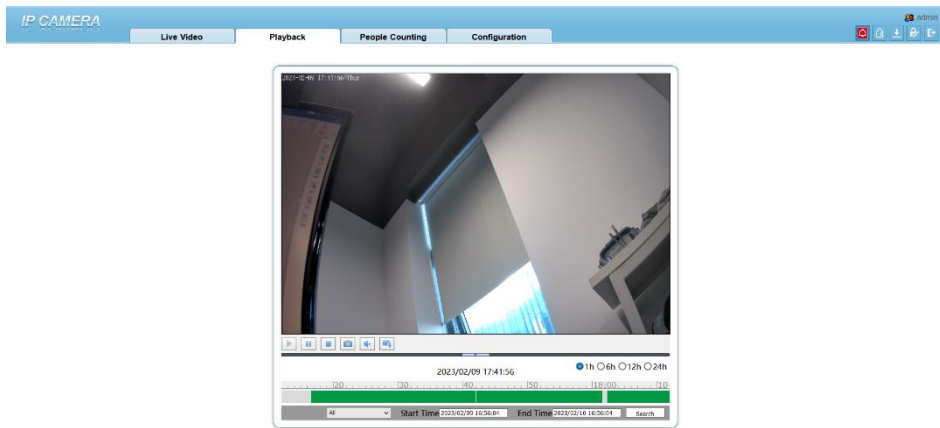

: Play, click “speaker” to switch sound on or off.



: Pause.



: Stop.



: Frame back / Frame play.



: Fast forward, user can choose the different speed to play.



: Snapshot, click the icon to snapshot current interface



: Backup, click the icon to start backup, drag the bar to download recording quickly, click the icon again to end up. The pop-up window of tip as shown in Figure 3-13, click the save to save the video. Click **Cancel** to abandon.

Figure 3-13 Record backup tip

Tip

Media Type	Mp4
Start Time	<input type="text" value="2023/02/09 17:44:29"/>
End Time	<input type="text" value="2023/02/09 17:45:16"/>

- All
 - Alarm Record
 - I/O Alarm
 - Motion Alarm
 - Day Night Switch Alarm
 - Audio Abnormal Alarm
 - Intrusion
 - Smart Motion
 - Single Line Crossing
 - Double Line Crossing
 - Multi-Loitering
 - Retrograde
 - Personnel Count Threshold Alarm
 - Network Alarm
- All Start Tim

Choose the type of alarm, set the start time and end time to search alarm record quickly.

3.6 People Counting (Only for Some Models)

At **people counting** interface, you can view the personnel count throughout setting query condition (choose the detail time at date's pop-up window).

There are three modes to show the data, such as line chart, histogram, and list, as shown in Figure 3-14

Figure 3-14 People counting interface

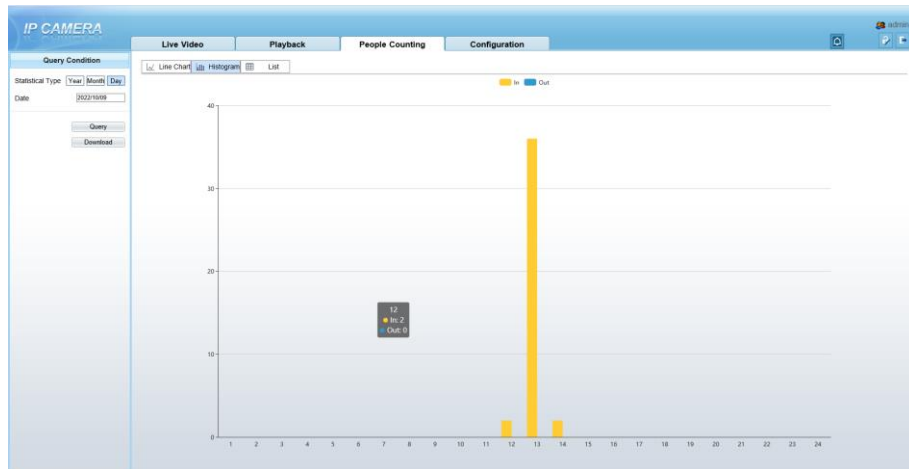

Click “Download” to download the query result.

Choose the mode of showing result, such as line chart, histogram and list.

Click “Query” to query the data of people counting.

The data result can be saved to local folder.

3.6.2 Set Local Network Parameters

Description

Local network parameters include:

- IP protocol
- IP address
- Subnet mask
- Default gateway
- Dynamic Host Configuration Protocol (DHCP)

- Preferred Domain Name System (DNS) server
- Alternate DNS server
- MTU

Procedure

Step 1 Choose **Configuration > Device > Local Network**.

The **Local Network** page is displayed, as shown in Figure 3-15.

Figure 3-15 Local Network page

Local Network

Network Card ID: 1

IP Protocol: IPv4

DHCP: OFF

IP Address: 192.168.0.120

Subnet Mask: 255.255.255.0

Default Gateway: 192.168.0.1

Preferred DNS Server: 192.168.0.1

Alternate DNS Server: 192.168.0.2

MTU(1280-1500): 1500

Refresh Apply

Step 2 Set the parameters according to Table 3-2.

Table 3-2 Local network parameters

Parameter	Description	Setting
IP Protocol	IPv4 is the IP protocol that uses an address length of 32 bits.	[Setting method] Select a value from the drop-down list box. [Default value] IPv4

Parameter	Description	Setting
DHCP	The device automatically obtains the IP address from the DHCP server.	[Setting method] Click the option button. NOTE To query the current IP address of the device, you must query it on the platform based on the device name.
DHCP IP	IP address that the DHCP server assigned to the device.	N/A
IP Address	Device IP address that can be set as required.	[Setting method] Enter a value manually. [Default value] 192.168.0.120
Subnet Mask	Subnet mask of the network adapter.	[Setting method] Enter a value manually. [Default value] 255.255.255.0
Default Gateway	This parameter must be set if the client accesses the device through a gateway.	[Setting method] Enter a value manually. [Default value] 192.168.0.1
Preferred DNS Server	IP address of a DNS server.	[Setting method] Enter a value manually. [Default value] 192.168.0.1
Alternate DNS Server	IP address of a domain server. If the preferred DNS server is faulty, the device uses the alternate DNS server to resolve domain names.	[Setting method] Enter a value manually. [Default value] 192.168.0.2
MTU	Set the maximum value of network transmission data packets.	[Setting method] Enter a value manually. NOTE The MTU value is range from 1280 to 1500, the default value is 1500, Please do not change it arbitrarily.

Step 3 Click **OK**.

- If the message "Apply success" is displayed, click OK. The system saves the settings. The message "Set network param's success, please login system again" is displayed. Use the new IP address to log in to the web management system.
- If the message "Invalid IP Address", "Invalid Subnet Mask", "Invalid default gateway", "Invalid primary DNS", or "Invalid space DNS" is displayed, set the parameters correctly.



NOTE

- If you set only the **Subnet Mask, Default Gateway, Preferred DNS Server**, and **Alternate DNS Server** parameters, you do not need to log in to the system again.
- You can click **Reset** to set the parameters again if required.

----**End**

4 PTZ Function Application

4.1 PTZ Control function

PTZ interface is only for cameras with motorized lens or with PTZ, not for all models. please refer to actual product.





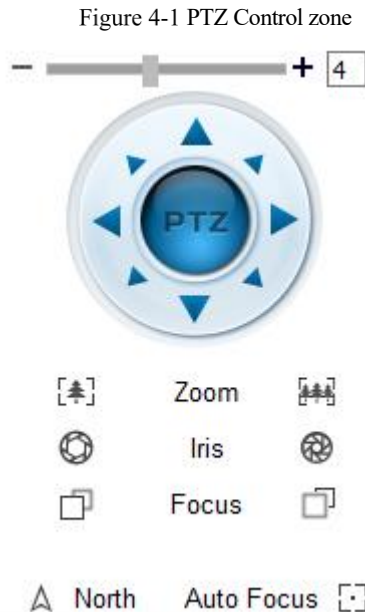



When browsing real-time videos shot by a dome camera or a camera connected to an external PTZ, you can control the PTZ to view Video shot in different directions.

In the PTZ control area, you can click the eights arrow keys to move the PTZ in eight directions, as shown in Figure 4-1.



It may also control the iris, zoom and focus of the camera lens through other buttons in the PTZ control zone. Functions of each button are as shown in Table 4-1.

Table 4-1 Descriptions of PTZ buttons

Button	Description
Auto Zoom	Click  or  to adjust the surveillance range of the front-end lens.
Auto Iris	Click  or  to adjust the size of the front-end iris.
Auto Focus	Click  or  to adjust the focus of the front-end lens.
Speed	Drag the slider on  to adjust the rotational speed of the PTZ.
North	Click  to set due north direction.
Focus	Click  to enable automatic focus function

----End

4.2 PTZ configuration

4.2.1 PTZ Setting

At live video interface, the PTZ configuration area displayed, as shown in Figure 4-2.

Figure 4-2 PTZ Configuration

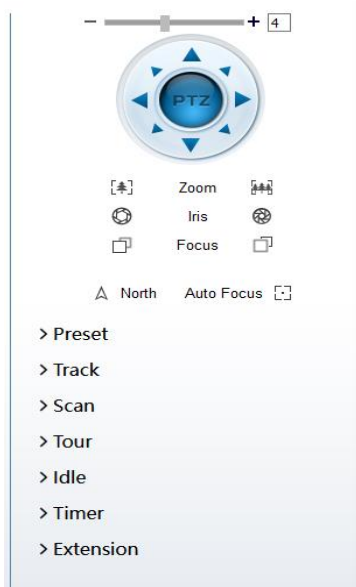

Through this interface, you can perform the following operations:

- Add, Delete and Apply a Preset, Track, Scan and Tour.
- Set and enable Idle.
- Set the direction to due north.
- Any direction can be set as the reference due north.
- Configure Timer.

----End

4.2.2 Configure and Apply Preset

You can configure preset positions and quickly rotate the camera to preset position by applying the preset.

Operation procedure

- Step 1 Click **Preset** in the PTZ configuration interface, the add preset page is displayed, as shown in Figure 4-3.

Figure 4-3 Add Preset

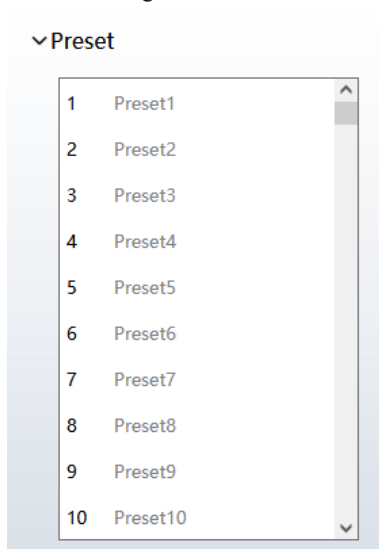

Step 2 Choose the preset ID.

Step 3 Adjust the direction of PTZ to finish the preset position setting.

Step 4 Click  to save, click to rename.

Step 5 Invoke a preset position. Select a preset position from the **Preset** list to invoke the preset position. Click  icon to invoke.

 **NOTE**

Up to 400 Presets can be configured

----End

4.2.3 Configure and Apply Tracks

You can record a track to allow the camera to repeatedly rotate based on the preset track.

Operation procedure

Step 1 Click **Track** in the PTZ configuration interface, the add track page is displayed as shown in Figure 4-4.

Figure 4-4 Add Track

The screenshot shows a configuration window titled 'Track' with a dropdown arrow. Below the title is a list of six tracks, numbered 1 to 6, with names 'Track1' through 'Track6'. Below the list is a section titled 'Add Track' containing an 'ID' dropdown menu set to '1', a 'Name' text input field, a play button (▶), and a stop button (■).

Step 2 Set the track ID and name.

Step 3 Click  to set the starting position of the track.

Step 4 Use arrow keys in the PTZ Control area to set a required a track.

Step 5 Click  to finish the track setting.

Step 6 Select a track name from the **Track** list, click  to invoke the track.

NOTE

Up to 6 Tracks can be configured.

----End

4.2.4 Configure and Apply Scan

You can configure a Scan to rotate the camera between two positions by applying the Scan.

Operation procedure

Step 1 Click **Scan** in the PTZ configuration interface, the add Scan page is displayed, as shown in Figure 4-5.

Figure 4-5 Add Scan

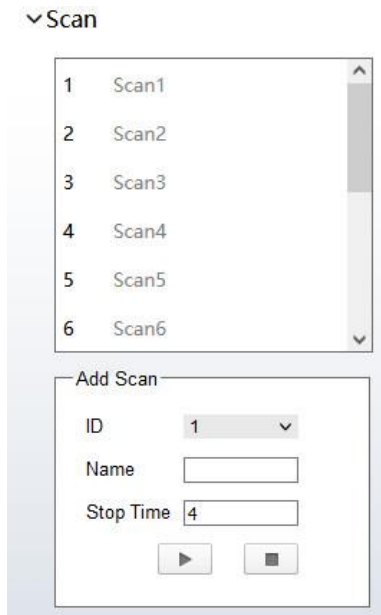

Step 2 Set the scan ID and name.

Step 3 Click .

Step 4 Use arrow keys in the **PTZ Control** area to set a start point and an end point.

Step 5 Click  to finish the scan setting.

Step 6 Select a scan value from the **Scan** list box, click  to invoke the scan.

---End

4.2.5 Configure and Apply Tour

You can configure a tour to rotate the camera between presets set by PTZ.

Operation procedure

Step 1 Click **Tour** the PTZ configuration interface, the add tour page is displayed, as shown in Figure 4-6.

Figure 4-6 Add Tour

▼ Tour

Tour

Preset

Wait Time

Add Tour

ID

Name

Preset

Wait Time

Step 2 Set the tour ID and name.

Step 3 Select a preset and set the wait time and click .

Step 4 Continue to select a preset and set the wait time and click .

Step 5 Repeat the step 3 and step 4 to add more presets.

Step 6 Click to finish the tour setting. Select a tour name and preset from the tour and preset drop-down list box, and then click to apply the tour.

---End

4.2.6 Configure and Apply Idle

You can configure an idle to `apply preset. Scan, Track, or Tour regularly.

Operation procedure

Step 1 Click **Idle** in the PTZ configuration interface, the idle page is displayed, as shown in Figure 4-7.

Figure 4-7 Idle



- Step 2 Enable the Idle button.
- Step 3 Set the idle type and name from list.
- Step 4 Set the wait time(1 min ~240 min).
- Step 5 Click to finish the idle setting.

---End

4.2.7 Configure Timer

Operation procedure

- Step 1 Click **Timer** in the PTZ configuration interface, the set timer page is displayed, as shown in Figure 4-8.

Figure 4-8 Set Timer

Timer	Begin Time	End Time	PTZ Type	Name	Clear
1	00:00	00:00	▼	▼	✕
2	00:00	00:00	▼	▼	✕
3	00:00	00:00	▼	▼	✕

Step 2 Set the Timer Mode. Timer mode includes Everyday and Once. You should set the time when once mode is selected.

Step 3 Choose Once, click Time to choose day from the pop-up calendar.

Step 4 Set Timers.

Select the begin time, end time, PTZ type and name from the drop-down list box.

Step 5 Click  to complete timer setting.

---End

4.2.8 Configure Extension

You can use extension function including lamp and brush.

Operation procedure

Step 1 Click **Extension** in the PTZ configuration interface, the extension page is displayed, as shown in Figure 4-9.

Figure 4-9 Extension

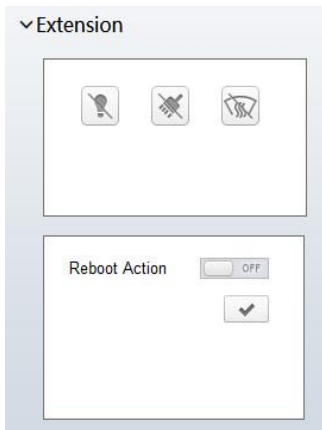

Step 2 Click  to enable the lamp.

Light On/Off is used to control the infrared camera shields on and off. It's available only to specific camera shields.

Click  to enable the brush.

Brush is used to clean the lens. It's available only to a camera with a brush or a camera shield.

Click  to enable the heater.

Heater is used to defog. It's available only to a camera with a heater.

 **NOTE**

- **Brush** is available only to a camera with a brush or a camera shield.
- **Light On/Off** is available only to specific camera shields.
- Reboot Action

The camera will perform the selected PTZ type and name when the camera reboots and the reboot action is enabling.

- Click the reboot action button to enable reboot action.
- Set the PTZ Type and name from the drop-down list box.
- Click  to finish the reboot setting.

----End

5 Transportation, storage and maintenance

5.1 Transportation

The packaged product can be delivered in all modes of transportation but without direct rain or snow.

5.2 Storage

This product can be stored for one year in an environment: devoid of corrosive substance, no obvious vibration, temperature range: 0° C~+40 ° C and humidity no more than 90%.

5.3 Maintenance

- Six months after putting into service:
 1. Check all the fasteners;
 2. Inspect the cables to ensure that protective sheath is not damaged and the cables will not come into touch with other objects during rotation.
- Five years after putting into service: the rubber sealing ring need to be replaced if the camera was installed in severe conditions, please contact the local distributor for this work.

5.4 Trouble-shooting

Phenomenon	Analysis	Solution
No image	No power supply	Check the power supply
	Poor connection of video signal cable	Check the video signal cable
Cannot switch to night viewing model	Strong light in optical angle/ in manual night viewing switch model	Remove the strong light Set to auto night viewing switch model

Unclear image	Camera is in manual focus model/ dust or stain on window	Set to auto model/ clear the window
Unstable image	Poor connection of video signal cable	Check the video signal cable
	Bad connection of signal cable	Check signal cable connection
	Signal attenuation caused by long distance	Use repeater to lengthen the communication distance
	Signal reflection	Short-circuit the 120-jumper wire of the farthest camera communication PCB, add 120 Ω to eliminate the reflection
	Incorrect address	Set according to instruction manual of camera
	Incorrect protocol	
Incorrect baud rate		
Uncontrolled camera	Incorrect model of camera	
	Incorrect setting of control model (SW1)	

A Troubleshooting

Common Trouble	Possible Cause	Solution
Unable to access the web	Network is not connected.	<ul style="list-style-type: none"> • Connect the network cable of the camera to the PC to check whether the network cable is in good contact. • Run the ping command to check the network connection and whether the device works normally.
	IP address is occupied.	Directly connect the camera to the PC, and reset the IP address of the camera.
	The IP addresses of the PC and the device are in different networks.	Check the IP address, subnet mask and gateway setting of the camera.
PTZ or high speed dome is out of control.	The protocol, bit-rate, or address setting of the PTZ is incorrect.	Modify the address of the PTZ on the web.
	The signal cable is unconnected or not connected correctly.	Check the signal strength, and reconnect the signal cable.
An error occurs in accessing the web of the device after the upgrade.	The data in the cache of browser is not updated in time.	<p>Delete the cache of the Internet Explorer. The steps are as follows (taking IE9 as an example):</p> <ol style="list-style-type: none"> 1. Open the Internet Explorer. 2. Select Tools > Internet Options. 3. On the General tab, select Delete under Browsing history. The Delete Browsing History dialog box appears. 4. Select all check boxes. 5. Click Delete. <p>Relogin the web page of the camera.</p>

Common Trouble	Possible Cause	Solution
Upgrade failed.	No network cable is connected.	Ensure the upgrade network is connected.
	The network setting is incorrect.	Check whether the network setting is correct.
	The upgrade package is incorrect.	Perform the correct upgrade package again.
No self-test no image output	There is a broken line in the circuit	Find breakpoints, rewiring.
	Low supply voltage	Replace the power adapter to increase the output voltage.
Self-test exception	Low supply voltage	Replace the power adapter to increase the output voltage.
Equipment control is normal, image instability (Analog video)	Poor video circuit contact	Troubleshooting, rewiring
	Access device exception	Replacement access device
Equipment control is normal, image instability (Web video)	Network line bad contact	Dismantling bad point, re-wiring.
	Access to computer performance is insufficient, take up CPU usage	Lower stream and resolution
	Lack of network bandwidth	Replacement of industrial Gigabit switches
	Access decoder performance decoder	Replacement of high-performance
Self-test normal, cannot control	Wrong wiring	Rewiring
	Set the baud rate, protocol, address and device mismatch	Screen configuration according to device parameters
Repeated restart	Insufficient supply voltage or voltage instability	To ensure that the input device voltage stability

Common Trouble	Possible Cause	Solution
Cannot control the lens to perform zoom and Focus action	Wiring error	Re-connect the lens control line
	Circuit board lens control problems	Replacement circuit board (please contact after-sales rework processing, do not replace parts or repair)
Cannot recall the set lens preset point	DIP switch relative to the set lens preset dialing is not set to ON	DIP switch control lens preset dialing dial into ON
The image is lost when the control device rotates	Rotation process at the same location lost image	Conductive slip ring there is a bad contact, replace the parts (please contact after-sales rework, do not replace parts or repair)

101-200-0158-01