

# Bi-Spectral PTZ Network Camera User Manual



**Issue**

**V 1.0**

**Date**

**2023-10-27**









# Precautions

## Precautions

Fully understand this document before using this device, and strictly observe rules in this document when using this device. If you install this device in public places, provide the tip "You have entered the area of electronic surveillance" in an eye-catching place. Failure to correctly use electrical products may cause fire and severe injuries. To prevent accidents, carefully read the following context:

## Symbols

This document may contain the following symbols whose meanings are described accordingly.

Symbol	Description
 <b>DANGER</b>	It alerts you to fatal dangers which, if not avoided, may cause deaths or severe injuries.
 <b>WARNING</b>	It alerts you to moderate dangers which, if not avoided, may cause minor or moderate injuries.
 <b>CAUTION</b>	It alerts you to risks. Neglect of these risks may cause device damage, data loss, device performance deterioration, or unpredictable results.
 <b>LASER RADIATION</b>	represents laser radiation
 <b>TIP</b>	It provides a tip that may help you resolve problems or save time.
 <b>NOTE</b>	It provides additional information.



To prevent electric shocks or other dangers, keep power plugs dry and clean.



- Strictly observe installation requirements when installing the device. The manufacturer shall not be held responsible for device damage caused by users' non-conformance to these requirements.
- Strictly conform to local electrical safety standards and use power adapters that are marked with the LPS standard when installing and using this device. Otherwise, this device may be damaged.
- Use accessories delivered with this device. The voltage must meet input voltage requirements for this device.
- If this device is installed in places with unsteady voltage, ground this device to discharge high energy such as electrical surges in order to prevent the power supply from burning out.
- When this device is in use, ensure that no water or any liquid flows into the device. If water or liquid unexpectedly flows into the device, immediately power off the device and disconnect all cables (such as power cables and network cables) from this device.
- Do not expose the thermal imaging camera or unpacked product to extremely strong radiation sources, such as the sun, laser, or arc welding machine, regardless of whether the device is being electrified or not; do not put the camera close to high thermal objects such as the sunlight; otherwise, the precision of the camera may be affected and even the detector inside the camera may suffer a permanent damage.
- If this device is installed in places where thunder and lightning frequently occur, ground the device nearby to discharge high energy such as thunder strikes in order to prevent device damage.



### CAUTION

- Unless otherwise specified, do not use the camera in a temperature lower than -10°C (+14°F) or higher than +50°C (+122°F). Too-high or too-low temperature may cause image display anomaly of the camera and the camera will be damaged if it is working under such a condition for a long time.
- If the camera is installed outdoors, avoid direct sunlight at dawn and dusk on the camera lens and install a sunshield with frontal and rear positions adjusted according to the sunlight angle.
- Avoid heavy loads, intensive shakes, and soaking to prevent damages during transportation and storage. The warranty does not cover any device damage that is caused during secondary packaging and transportation after the original packaging is taken apart.
- Protect this device from fall-down and intensive strikes, keep the device away from magnetic field interference, and do not install the device in places with shaking surfaces or under shocks.
- Clean the device with a soft dry cloth. For stubborn dirt, dip the cloth into slight neutral cleanser, gently wipe the dirt with the cloth, and then dry the device.
- Since the camera lens is painted with a durable coating material, it adapts to outdoor environment. The lens must be cleaned regularly. If the image quality is

reduced or excessive dirt is deposited on the lens, clean the lens in a timely manner. In sandy (in desert) or corrosive (on sea) environment, use the camera with caution; improper use may cause the coating to peel off.

- Do not jam the ventilation opening. Follow the installation instructions provided in this document when installing the device.
- Keep the device away from heat sources such as radiators, electric heaters, or other heat equipment.
- Keep the device away from moist, dusty, extremely hot or cold places, or places with strong electric radiation.
- If the device is installed outdoors, take insect- and moisture-proof measures to avoid circuit board corrosion that can affect monitoring.
- Remove the power plug if the device is idle for a long time.
- Before unpacking, check whether the fragile sticker is damaged. If the fragile sticker is damaged, contact customer services or sales personnel. The manufacturer shall not be held responsible for any artificial damage of the fragile sticker.



### **LASER RADIATION**

- If the camera uses laser beam equipment, you need to pay attention to the following points.
- Laser can cause damage to human eyes. It is strictly prohibited to shoot laser at people within 50m in front of the camera.
- Laser radiation can cause permanent damage to skin and eyes, and can also ignite flammable items. Therefore, you should avoid directly exposing any items (except scattering terminals or absorbers) to the laser beam, and do not expose some volatile substances to the laser beam. Place flammable items (such as alcohol) in the working area of laser radiation products to avoid laser irradiation or high-voltage discharge sparks that may cause fires.
- In the working area of laser radiation products, all objects that produce specular reflection should be removed, because even the reflected or scattered light of the laser still has a very high intensity and is enough to cause damage to the eyes.
- If such items must be used, necessary measures should be taken to control their reflection and scattering ranges. If disassembly, relocation, etc. are required, please wait 5 minutes after the laser rangefinder is completed to ensure that the accumulated charge inside it is released before proceeding to prevent electric shock due to accumulated charge.
- It is strictly prohibited to touch the rangefinder circuit during operation, especially the laser power supply with high voltage above kilovolts.
- It is strictly prohibited to plug or unplug cables while the power is on.

## Special Announcement

All complete products sold by the manufacturer are delivered along with nameplates, operation instructions, and accessories after strict inspection. The manufacturer shall not be held responsible for counterfeit products.

This manual may contain misprints, technology information that is not accurate enough, or product function and operation description that is slightly inconsistent with the actual product. The manufacturer will update this manual according to product function enhancement or changes and regularly update the software and hardware described in this manual. Update information will be added to new versions of this manual without prior notice.

This manual is only for reference and does not ensure that the information is totally consistent with the actual product. For consistency, see the actual product.

---

# Contents

---

<b>Precautions</b> .....	<b>i</b>
Precautions .....	i
Symbols.....	i
Special Announcement.....	iv
<b>Contents</b> .....	<b>v</b>
<b>1 Overview</b> .....	<b>1</b>
1.1 Principle of Thermal Imaging and Advantages .....	1
1.2 Product Introduction.....	1
1.2.1 Function .....	2
1.2.2 Product Features.....	2
1.3 Description of PTZ cable .....	3
1.3.1 Multi-cable .....	3
1.3.2 Aviation Alarm Cable .....	4
<b>2 Device Dimensions</b> .....	<b>7</b>
<b>3 Device Installation</b> .....	<b>8</b>
3.1 Installation Method .....	8
3.2 Device Installation.....	8
3.2.1 Installation of Basic Requirements.....	8
3.2.2 Basic Installation Tool.....	8
3.2.3 Installation Space and Installation Strength .....	9
3.2.4 Definition of Installation Wiring Harness .....	9
<b>4 Quick Configuration</b> .....	<b>11</b>
4.1 Thermal Web .....	11
4.1.1 Login and Logout.....	11
4.1.2 Main Page Layout .....	12
4.1.3 Change the Password .....	13
4.1.4 Browse Video .....	14
4.1.5 Install Plugins.....	15
4.1.6 People Counting.....	16
4.1.7 Set Local Network Parameters .....	16
4.1.8 Thermal Settings .....	19

4.1.8.1 Temperature Parameters .....	19
4.1.8.2 Ambient Temperature .....	23
4.1.8.3 Temperature Alarm.....	24
4.1.8.4 Privacy Zone Masking.....	28
4.1.8.5 Schedule Linkage .....	29
4.1.8.6 Defect Pixel Correction.....	30
4.1.8.7 Version Information.....	31
4.2 Visible-light Web.....	32
4.2.1 Login and Logout.....	32
4.2.2 Main Page Layout .....	33
4.2.3 Change the Password .....	34
4.2.4 Browse Video.....	35
4.2.5 Install Plugins.....	36
4.2.6 Set Local Network Parameters.....	37
<b>5 Thermal Image Settings.....</b>	<b>40</b>
5.1 Access the Image Settings Interface .....	40
5.2 Image Settings Parameter description .....	41
5.2.1 Mode.....	41
5.2.2 Image .....	42
5.2.3 Scene.....	43
5.2.4 Set Pseudocolor .....	44
5.2.5 FFC Control .....	45
5.2.6 Noise Reduction.....	46
<b>6 Visible-light Parameter Configuration.....</b>	<b>48</b>
6.1 Access the Image Settings Interface .....	48
6.2 Sensor Setting Parameter description .....	49
6.2.1 Mode.....	49
6.2.2 Image .....	50
6.2.3 Scene.....	51
6.2.4 Exposure .....	52
6.2.5 WB Setting.....	53
6.2.6 Daynight.....	55
6.2.7 Noise Reduction.....	57
6.2.8 Enhance Image.....	58
6.2.9 Zoom Focus .....	60
<b>7 PTZ Function Application.....</b>	<b>62</b>



7.1 PTZ Control function .....	62
7.2 PTZ configuration .....	63
7.2.1 PTZ setting.....	63
7.2.2 Configure and Apply Preset .....	64
7.2.3 Configure and Apply Tracks .....	64
7.2.4 Configure and Apply Scan .....	65
7.2.5 Configure and Apply Tour.....	66
7.2.6 Configure and Apply Bow Scan.....	67
7.2.7 Configure and Apply Idle.....	68
7.2.8 Configure Timer.....	69
7.2.9 Configure Extension.....	70
<b>8 Intelligent Analysis.....</b>	<b>72</b>
8.1 Intrusion .....	72
8.2 Single Line Crossing .....	75
8.3 Double Line Crossing.....	78
8.4 Multi-Loitering.....	80
8.5 Wrong-way.....	83
8.6 People Counting.....	86
8.7 Enter Area .....	89
8.8 Leave Area .....	91
<b>9 AI Multiobject of Thermal Channel .....</b>	<b>94</b>
9.1 Parameters of AI Multiobject .....	94
<b>10 AI Multiobject of Visible Channel.....</b>	<b>96</b>
10.1 AI Configuration .....	96
<b>A Troubleshooting.....</b>	<b>99</b>
<b>B Common Emission Rate.....</b>	<b>102</b>



# 1 Overview

## 1.1 Principle of Thermal Imaging and Advantages

Any object with temperature higher than the absolute zero (-273.15° F) will emit infrared (IR) ray, even though it does not emit light. The IR ray is also called thermal radiation. IR rays emitted by objects with different temperatures can be absorbed by the detector to reflect temperature change and thus generate an electric effect. The electric signal is amplified and processed to produce a thermal image that corresponds to the thermal distribution of the object surface. This is the process of thermal imaging.

- Adapt to any environment

Traditional cameras rely on natural or environmental light to shoot images, but this IR thermal imaging camera relies on the IR energy radiated by an object itself to form an image, not requiring any light. The IR thermal imaging camera is applicable to any environment and not affected by light strength. It can detect and identify any camouflage and concealed object both in daytime or nighttime, implementing round-the-clock monitoring.

- Monitor the temperature field with object energy distributed

The IR thermal imaging camera can show the temperature field of an object, converting the invisible surface temperature distribution situation to a visible thermal image that reflects the surface temperature distribution situation of the object. By this monitoring, users can discover temperature anomaly in a timely manner and take precautionary measures to avoid any risk that may be caused by the anomaly, for example, a fire.

- Boast cloud penetration capability

Visible light and near IR ray will be absorbed by the air, cloud and smoke, but they are transparent to IR ray of the 3~5 μm Medium Wavelength Infrared (MWIR) region and 8~14 μm Long Wavelength Infrared (LWIR) region. Traditional cameras cannot shoot clear images under cloudy environment, but the IR thermal imaging camera can penetrate the cloud and smoke to shoot clear images.

## 1.2 Product Introduction

Bi-Spectral PTZ Network Camera, the whole machine shell and the base are all made of high strength aluminum alloy material with comprehensive function and high stability. Can adapt to a variety of bad environment, heavy load can reach more than 50kg and run smoothly. This series has 360°continuous rotation,

automatic scanning, automatic cruise and other functions, suitable for large areas of monitoring, can be widely used in airports, stations, urban roads, traffic survey and monitoring, forest fire prevention, the high and heavy equipment rotary control and other important area.

### 1.2.1 Function

- To support a variety of scanning methods, such as cruise scan, pattern scanning, etc.
- It supports the function of power off memory and automatically returns to the monitoring scene before power off.
- Support network signal and analog signal double output, cloud platform control classification operation.
- The double helix structure of worm gear and worm drive, the electronic image stabilization, and mechanical locking design, power self-locking function.
- Horizontal continuous rotation  $360^\circ$ , vertically  $+90^\circ \sim -90^\circ$  rotating, horizontal velocity is  $0.01 \sim 60$  °/S, vertical speed of  $0.01 \sim 30$  °/S
- Support proportion variable times function, rotation speed adjusted automatically according to the lens change multiple times.
- Support watch features preset point/figure/cruise can stay idle scan specified Automatic call after time (including the idle state entered after power).

### 1.2.2 Product Features

- The shell of the machine adopts the material of high strength aluminum alloy die casting machine with anti-corrosion materials, anti-corrosion treatment, key parts filling nitrogen seal, all-weather protective design, IP66 protection grade, can adapt to the maritime and coastal defense environment such as salt fog video monitoring application.
- Double spiral worm gear transmission structure, mechanical anti-loosening design, power-off self-lock, strong wind resistance, high stability. Worm gear and worm drive design, level  $360^\circ$  continuous rotation, horizontal speed can reach  $60^\circ/\text{s}$
- Support multiple lens prepositioning function, change the adaptive function, the rotation speed can be adjusted according to the lens multiple times.
- Preset accuracy can be up to  $\pm 0.1^\circ$ .
- Through the rain and fog: the common feature of thermal imaging products is that they are not affected by the rain and fog. Even in the forest, the frequent occurrence of rain and fog in the coastal areas can clearly capture the observed targets.
- Maximum support for 100mm thermal imaging lens design.
- The imaging is clear: the thermal imaging system is able to produce clear and penetrating images through the dark environment with no light, the image is clear, the focal length is fine, and the optical fog is supported.
- The machine assembly is easy to operate and easy to maintain.

## 1.3 Description of PTZ cable

### 1.3.1 Multi-cable

Aviation power supply and network cable of twenty-six cores is shown as Figure 1-1 &Figure 1-2, and the description is shown in Table 1-1.

Figure 1-1 Aviation power supply and network cable of twenty-six cores



Figure 1-2 Definition of twenty-six cores

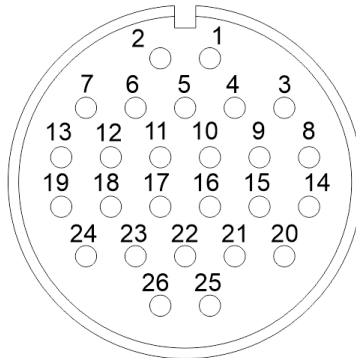

Table 1-1 Description of twenty-six cores

SN	Name	Description
1	DC36V -	Black (Thick)
2	DC36V +	Red (Thick)

SN	Name	Description
3	DC36V -	Black (Thick)
4	DC36V -	Black (Thick)
5	Alarm_OUT1	Red (Thin)
6	DC36V +	Red (Thick)
7	DC36V +	Red (Thick)
8	Audio_IN(G)	Audio masking
9	Audio_IN	Audio Core
10	Alarm_OUT1	Black (Thin)
11	Alarm_OUT3	Blue
12	Alarm_OUT3	Pink
13	Alarm_OUT4	White
14	Audio_OUT(G)	Audio masking
15	Audio_OUT	Audio Core
16	Video	Video Core
17	Video (G )	Video masking
18	Alarm_OUT2	White and Orange
19	Alarm_OUT4	Green
20	RS485A	Orange (Thick)
21	RS485B	Yellow (Thick)
22	ETHTX+	White and Orange
23	ETHTX-	Orange
24	Alarm_OUT2	White and Yellow
25	ETHRX+	White and Green
26	ETHRX-	Green

### 1.3.2 Aviation Alarm Cable

Aviation alarm cable of twenty-six cores is shown as Figure 1-3& Figure 1-4, and the description is shown in Table 1-2.

Figure 1-3 Aviation power supply cable of twenty-six cores



Figure 1-4 Definition of twenty-six cores

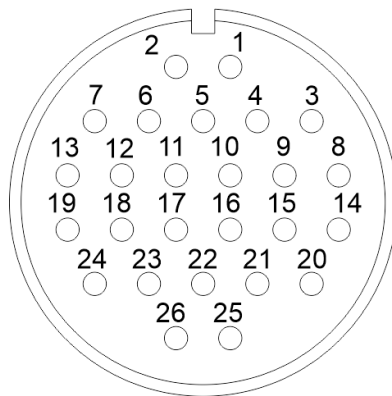

Table 1-2 Description of twelve cores

SN	Name	Description
1	Reserved core	Blank

SN	Name	Description
2	Reserved core	Blank
3	Reserved core	Blank
4	Reserved core	Blank
5	Reserved core	Ground
6	Reserved core	Blank
7	Reserved core	Blank
8	Reserved core	Ground
9	Reserved core	Ground
10	Reserved core	Blank
11	Alarm_IN1	White
12	Alarm_IN2	White and Orange
13	Alarm_IN3	Blue
14	Audio IN(G)	Audio masking
15	Audio_IN	Audio Core
16	Video	Video Core
17	Video (G)	Video masking
18	Audio_OUT	Audio Core
19	Audio_OUT(G)	Audio masking
20	Alarm_IN4	Pink
21	Alarm_IN5	Red (Thin)
22	Alarm_IN6	White and Yellow
23	Alarm_IN7	Blank
24	Alarm_IN8	Yellow (Thick)
25	Alarm_IN9	Orange (Thick)
26	Alarm_G	Black (Thick)

----End



# 2 Device Dimensions

Figure 2-1 shows the dimensions of the Bi-Spectral PTZ Network Camera.

Figure 2-1 Dimensions (unit: mm)

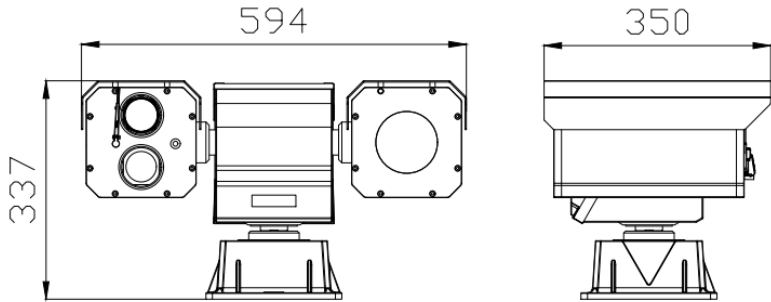

# 3 Device Installation

## 3.1 Installation Method

Bi-Spectral PTZ Network Camera can be installed on camera base.

Figure 3-1 shows the base dimensions of PTZ camera.

Figure 3-1 Base dimensions of PTZ camera (unit: mm)

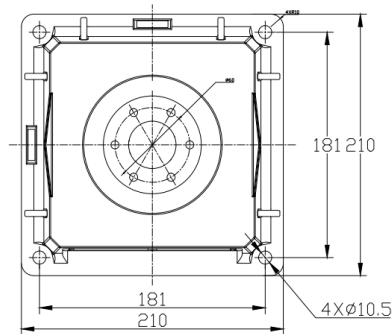

## 3.2 Device Installation

### 3.2.1 Installation of Basic Requirements

Installation site and environment meet the technical parameters mentioned in the requirements, the installation staff should have been fully read and read the contents of this manual, with the appropriate system installation qualification and maintenance work qualification certificate.

Because the PTZ is heavy, please be sure to connect the power test PTZ before installation, whether it can be started normally and self-test, whether the PTZ control is normal and its function is normal, and when it is normal, it will be installed on site.

### 3.2.2 Basic Installation Tool

Commonly used engineering wiring and equipment installation tools, please install the equipment before the preparation is complete.

Table 3-1 shows the installation tools list.

Table 3-1 Installation tools

Name	Quantity	Remarks
13mm wrench	1	For mounting fixtures and mounting brackets
14mm sleeve	1	
Cross screwdriver(big)	1	For common construction
Cross screwdriver(small)	1	Used to disassemble the DIP cover to adjust the device communication parameters
Inside the hex wrench	1 set	Used for disassembly of pan / tilt pallet and shield connection
Word screwdriver (small)	1	to secure the wiring harness connection terminals
Wire strippers	1	Stripping

### 3.2.3 Installation Space and Installation Strength

Under normal circumstances, this device needs to be equipped with a protective cover or other overhead items, please confirm the installation location can accommodate this product and the equipment and installation of the structure of the space. To confirm the installation of the wall, the carrying capacity of the bracket can reach 4 times the safety of the entire equipment weight.

Install the device as shown, using the bolts and nuts in the fitting.

### 3.2.4 Definition of Installation Wiring Harness

The bottom line includes power line, network cable, RS422, geodetic line, video line, and according to the demand, there are various types of outgoing line. The details need to be controlled according to the line signature of each device.

Table 3-2 shows Definition of installation wiring harness.

Table 3-2 Definition of installation wiring harness

COLOR	Function define	Remark
BNC	Video	Optional
Red	DC36V+	N/A
Black	DC36V-	
RJ45	Network cable	

COLOR	Function define	Remark
Orange	RS422 TX+	
Yellow	RS422 TX-	
Red	RS422 RX+	
Blue	RS422 RX-	
Yellow & Green	GND	

 **NOTE**

In order to prevent lightning strikes, the grounding wire (yellow-green wire) in the cable outlet base must be grounded reliably and the grounding resistance should be  $<4\Omega$ .

**----End**

# 4 Quick Configuration

## 4.1 Thermal Web

### 4.1.1 Login and Logout



#### CAUTION

You must use Edge/Chrome/Firefox to access the web management system; otherwise, some functions may be unavailable.

#### Login system

Step 1 Open the Internet Explorer, enter the IP address of IP camera (default value: 192.168.0.121) in the address box, and press Enter.

The login page is displayed, as shown in Figure 4-1.

Figure 4-1 Login page

The screenshot shows the login interface for an IP camera. It features a light blue header with the text 'IP CAMERA' in a large, bold, blue font. To the right of the header is a language selection dropdown menu currently set to 'English'. Below the header, there are two input fields: 'User Name' and 'Password'. To the right of these fields is a blue 'Login' button.

Step 2 Input the User name and password.

#### NOTE

- The default user name is **admin**. The default password is **admin**. Change the password when you login the system for first time to ensure system security.
- You can change the system display language on the login page.

Step 3 Click Login.

The main page is displayed.

----End

## Logout

To logout of system, click  in the upper right corner of the main page, the login page is display after you log out of the system.

## 4.1.2 Main Page Layout

On the main page, you can view Live video, set parameter, Video parameter, Video control, PTZ control, PTZ Configure and log out of the system. Figure 4-2 is shown the main page layout. Table 4-1 lists the elements on the main page layout.

Figure 4-2 Main page layout

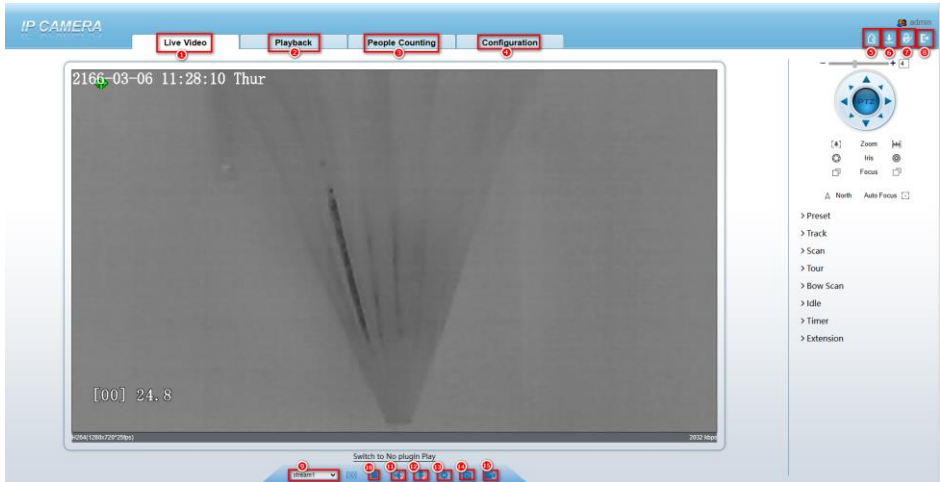









Table 4-1 Elements on the main page

No.	Element	Description
1	Live video area	Live videos are played in this area. You can also set sensor parameters.
2	Playback	You can query the playback videos in this area. NOTE Only when the SD card have videos that user can query the playback videos.
3	People Counting	You can query graph data about the number of people if the statistical function has been configured and statistical data is available.
4	Device configuration	You can choose a menu to set device parameters, including the device information, audio and video streams, alarm setting, and privacy mask function.

No.	Element	Description
5	Plugins of IP camera LocalServer	You can click  to download the plugins. If you use the device web page too frequencies. Suggest you Install the plugins first.
6	Backup Status	The icon  display the record video backup status. It display backup list and completion degree while you click the icon in non plug-in. And just display backup status in plug-in model.
7	Change password	You can click  to change the password.
8	Sign Out	You can click  to return to the login page.
9	Stream	Three are three streams. Choose one type from drop-down list.
10	Pause/Start	Close live video or play live video.
11	Audio	Open or close audio.
12	Interphone	Open or close interphone.
13	Setting	Click the icon, it will jump to configuration page.
14	Snapshot	Click the icon, it will snapshot.
15	Local record	Click the icon, it will record video and save.

### NOTE

1. When the device generates an alarm, the alarm icon  is displayed. You can click  to view the alarm information. When the device accepts an alarm signal, the alarm icon will display within 10s in the web management system.
2. When the device encounters an exception, the fault icon  is displayed. You can click  to view the fault information.

## 4.1.3 Change the Password

### Description

You can click  to change the password for logging in to the system.

### Procedure

Step 1 Click  in the upper right corner of the main page.

The **Change Password** dialog box is displayed, as shown in Figure 4-3.

Figure 4-3 Modify Password dialog box

Change Password

Old Password

New Password

Confirm

Password Advice:  
 1. Recommended password length is 8 characters  
 2. Recommended passwords contain numbers, lowercase characters, uppercase characters and special characters  
 3. Password and username are recommended to be different

OK Cancel

 **NOTE**

The change password page will be displayed if you don't change the default password when you login the system for the first time.

Step 2 Enter the old password, new password, and confirm password.

Step 3 Click **OK**.

If the message "Change password success" is displayed, the password is successfully changed. If the password fails to be changed, the cause is displayed. (For example, the new password length couldn't be less than eight.)

Step 4 Click **OK**.

The login page is displayed.

----**End**

#### 4.1.4 Browse Video

Users can view live video in web pages. Browsers like Edge/Chrome are recommended.

##### Preparation

There are two methods to play Live video, no-plugins and plugins. If you login web page use Edge application, the Live video be played by no-plugins method. This method requires high hardware performance for computer graphics cards.

So we suggest to ensure the Live video can be play properly, you had better perform install plugins in your computer, please following operation below :

Step 1 Open the Edge, login the web page. Click plugins  icon to download IP camera local Server plugins. The web page will pop up tip box after the download task finished, as shown in Figure 4-4

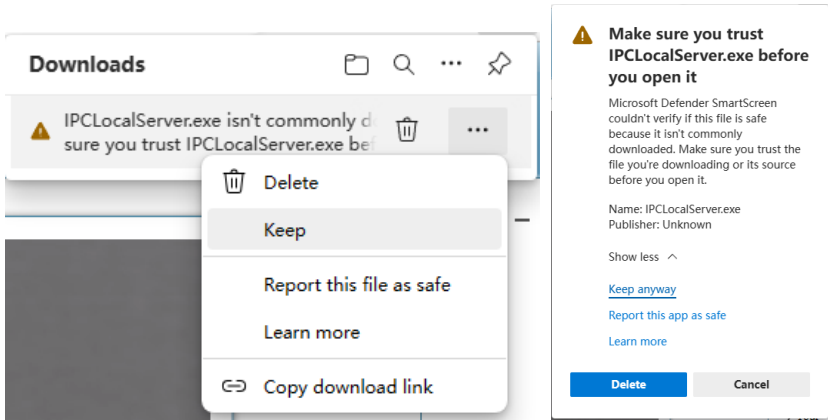

Figure 4-4 Tip download box



Step 2 Click icon **...**, it will pop up an operation options, click the title keep, then click keep away after the confirm box pop up, as show in Figure 4-5.

Figure 4-5 download plugins



Step 3 Then the IPCLocalServer.exe plugins download successful.

### 4.1.5 Install Plugins

You download the plugins before, then we need to install the plugins. Click open file or double click the IPCLocalServer.exe as shown in Figure 4-6 to start install process.

Figure 4-6 Download the plugin page



Step 1 It will pop up install box to help user to install plugins, you just need to click twice 'next' button, once 'install' button, once 'finish' button to finish the installation.

Step 2 Reopen or refresh the browser after installation, the plugins is going working.

**----End**

## 4.1.6 People Counting

Figure 4-7 People Counting Interface

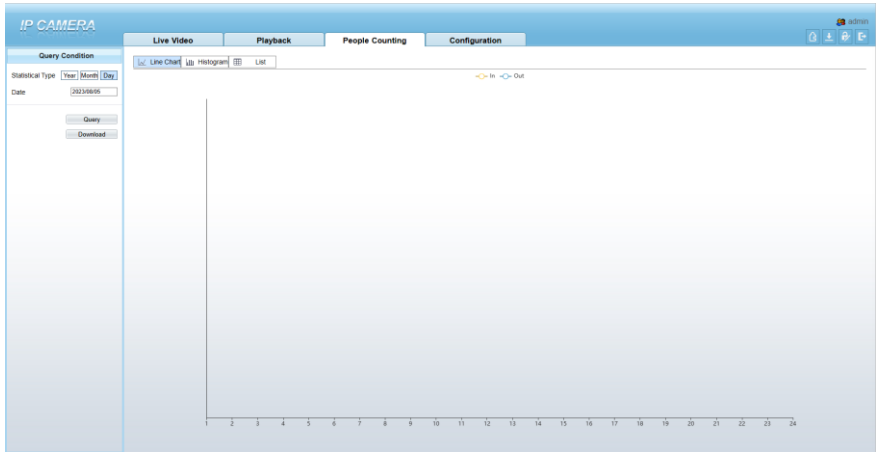

User can choose the querying mode (year, month, day).  
 The data can be viewed directly, or downloaded them.  
 The statistic can be showed by line chart, histogram, list.

## 4.1.7 Set Local Network Parameters

### Description

Local network parameters include:

- IP protocol
- IP address
- Subnet mask
- Default gateway
- Dynamic Host Configuration Protocol (DHCP)
- Preferred Domain Name System (DNS) server
- Alternate DNS server
- MTU

### Procedure

Step 1 Choose **Configuration > Device >Local Network**.

The **Local Network** page is displayed, as shown in Figure 4-8.

Figure 4-8 Local Network page

**Local Network**

Network Card ID: 1

IP Protocol: IPv4

DHCP: OFF

IP Address: 192.168.0.121

Subnet Mask: 255.255.0.0

Default Gateway: 192.168.0.1

Preferred DNS Server: 192.168.0.1

Alternate DNS Server: 192.168.0.2

MTU(800-1500): 1500

Refresh Apply

Step 2 Set the parameters according to Table 4-2.

Table 4-2 Local network parameters

Parameter	Description	Setting
IP Protocol	IPv 4 is the IP protocol that uses an address length of 32 bits.	[Setting method] Select a value from the drop-down list box. [Default value] <b>IPv 4</b>
DHCP	The device automatically obtains the IP address from the DHCP server.	[Setting method] Click the option button. NOTE To query the current IP address of the device, you must query it on the platform based on the device name.
DHCP IP	IP address that the DHCP server assigned to the device.	N/A
IP Address	Device IP address that can be set as required.	[Setting method] Enter a value manually. [Default value] <b>192.168.0.121</b>

Parameter	Description	Setting
Subnet Mask	Subnet mask of the network adapter.	[Setting method] Enter a value manually. [Default value] <b>255.255.255.0</b>
Default Gateway	This parameter must be set if the client accesses the device through a gateway.	[Setting method] Enter a value manually. [Default value] <b>192.168.0.1</b>
Preferred DNS Server	IP address of a DNS server.	[Setting method] Enter a value manually. [Default value] <b>192.168.0.1</b>
Alternate DNS Server	IP address of a domain server. If the preferred DNS server is faulty, the device uses the alternate DNS server to resolve domain names.	[Setting method] Enter a value manually. [Default value] <b>192.168.0.2</b>
MTU	Set the maximum value of network transmission data packets.	[Setting method] Enter a value manually. NOTE The MTU value is range from 800 to 1500, the default value is 1500, Please do not change it arbitrarily.

### Step 3 Click **OK**.

- If the message "Apply success" is displayed, click **OK**. The system saves the settings. The message "Set network param's success, Please login system again" is displayed. Use the new IP address to login to the web management system.
- If the message "Invalid IP Address", "Invalid Subnet Mask", "Invalid default gateway", "Invalid primary DNS", or "Invalid space DNS" is displayed, set the parameters correctly.

#### **NOTE**

- If you set only the **Subnet Mask**, **Default Gateway**, **Preferred DNS Server**, and **Alternate DNS Server** parameters, you do not need to login to the system again.
- You can click **Reset** to set the parameters again if required.

----**End**

## 4.1.8 Thermal Settings

### 4.1.8.1 Temperature Parameters

Temperature parameters include: temperature unit, ambient type, ambient temperature, cavity temperature, correctional coefficient and area temperature display mode.

#### Operation Procedure

Step 1 Choose **Configuration > Thermal > Temperature Parameters**.

The **Temperature Parameters** page is displayed, as shown in Figure 4-9.

Figure 4-9 Temperature Parameters interface

The screenshot displays the 'Temperature Parameters' configuration page. At the top, there is a title bar with a gear icon and the text 'Temperature Parameters'. Below this is a table of configuration options:

Temperature Measurements		ON
Temperature Units	Celsius	▼
Length Units	Meters	▼
Cavity Temperature	35.02	
Correction Coefficient	0.00	
Area ID Display Mode	Area ID	▼
Temperature Consume Mode	Close	▼
Area Temperature Display Mode	Low Left	▼
Font Border		ON
Font Size	Mid	▼
Area Temperature Type	Highest Temperature	▼
Measure Mode	General	▼
Display Alarm Area		OFF
Area Alarm Interval (1-1800s)	10	
Area Alarm Delay (0-10s)	0	
Temperature Range	-20.0 ~ 150.0	▼
Prevent Overheating	Auto	▼
Duration (5-60s)	60	

At the bottom of the configuration area, there is an 'Advanced' button. Below the entire configuration area, there are 'Refresh' and 'Apply' buttons.

Step 2 Set the parameters according to Table 4-3.

Table 4-3 Temperature parameters

Parameter	Description	Setting
Temperature Unit	Celsius and Fahrenheit temperature units are available.	[Setting method] Select a value from the drop-down list box. [Default value] <b>Celsius</b>
Length Units	The units of length.	[Setting method] Select a value from the drop-down list box. [Default value] Meters
Cavity Temperature	The cavity temperature of camera.	N/A
Correction Coefficient	Correction coefficient is refer to the deviation of measured object temperature and actual temperature. For example: 1. The measured object temperature is 30, and actual temperature is 37, so the correction coefficient should be 7. 2. The measured object temperature is 37, and actual temperature is 30, so the correction coefficient should be -7.	[Setting method] Enter a value manually. [Default value] <b>0.00</b>
Area ID Display Mode	The display mode of area.	[Setting method] Select a value from the drop-down list box. [Default value] Area ID
Temperature Consume Mode	The mode of temperature	[Setting method] Select a value from the drop-down list box. [Default value] Close

Parameter	Description	Setting
Area Temperature Display Mode	The display position of temperature information on the live-video image.	[Setting method] Select a value from the drop-down list box. [Default value] <b>Low left</b>
Font Border	Enable to bold the font	[Setting method] Enable or disable [Default value] <b>Disable</b>
Font Size	The size for temperature font in OSD	[Setting method] Select a value from the drop-down list box. [Default value] Mid
Area Temperature Type	There are three types of area temperature.	[Setting method] Select a value from the drop-down list box. [Default value] <b>Highest Temperature</b>
Measure Mode	There are two types measure modes.	[Setting method] Select a value from the drop-down list box. [Default value] <b>General</b>
Display Alarm Area	N/A	[Setting method] Enable or disable [Default value] <b>Disable</b>
Area Alarm Interval	N/A	[Setting method] Enter a value manually ranges from 1 to 1800. [Default value] <b>10</b>
Area Alarm Delay	The time delay of alarm.	[Setting method] Enter a value manually ranges from 0 to 10. [Default value] <b>0</b>

Parameter	Description	Setting
Temperature Range	The temperature range of detection area.	[Setting method] Select a value from the drop-down list box. [Default value] -20.0~150.0 Celsius -4.00~302.00 Fahrenheit
Prevent Overheating	Prevent overheating function: A heat source (sun) with too high a temperature can damage the detector. If detected, the shield will be lowered to provide protection	[Setting method] Select a value from the drop-down list box. [Default value] Auto
Duration	The time duration of prevent overheating.	[Setting method] Enter a value manually ranges from 5 to 60. [Default value] <b>60</b>

Figure 4-10 Advanced interface

The screenshot shows the 'Advanced' settings panel. It contains three rows of settings, each with a label and a dropdown menu:

- Dimming Mode:** Set to 'Auto'.
- Raw Data Upload Interval(F/S):** Set to '1'.
- Mix Stream Mode:** Set to 'Close'.

At the bottom right of the panel, there are two buttons: 'Refresh' and 'Apply'.

 **NOTE**

Advanced Settings are used to set different color image display in different temperature ranges, which can highlight the warning temperature

Table 4-4 Advance parameters

Parameter	Description	Setting
Dimming Mode	There are auto and manual modes. It will show on temperature item.	[Setting method] Select a value from the drop-down list box. [Default value] <b>Auto</b>



Parameter	Description	Setting
Raw Data Upload Interval	The interval of raw data upload	[Setting method] Select a value from the drop-down list box. [Default value] <b>1</b>
Mix Stream Mode	N/A	[Setting method] Select a value from the drop-down list box. [Default value] <b>Close</b>

Step 3 Click **Apply**.

The message "Apply success" is displayed, the system saves the settings.

----End

## 4.1.8.2 Ambient Temperature

Operation Procedure

Step 1 Choose **Configuration > Thermal > Ambient Temperature**.

The **Ambient Temperature** page is displayed, as shown in Figure 4-11

Figure 4-11 Ambient Temperature configuration

Ambient Temperature

Ambient Temperature  °C

Cavity Temperature  °C

Step 2 Set the parameters according to Table 4-6

Table 4-5 Ambient Temperature configuration

Parameter	Description	Setting
Ambient Temperature	The temperature in device ambient. If you not setup a parameter here, the device use cavity temperature to calculate the target temperature.	[Setting method] Enter a value manually ranges [Default value] <b>25</b>
Cavity Temperature	The internal temperature of device.	N/A

### 4.1.8.3 Temperature Alarm

#### Operation Procedure

Step 1 Choose **Configuration > Thermal > Temperature Alarm**.

The **Temperature Area** page is displayed, as shown in Figure 4-12

Figure 4-12 Temperature alarm configuration

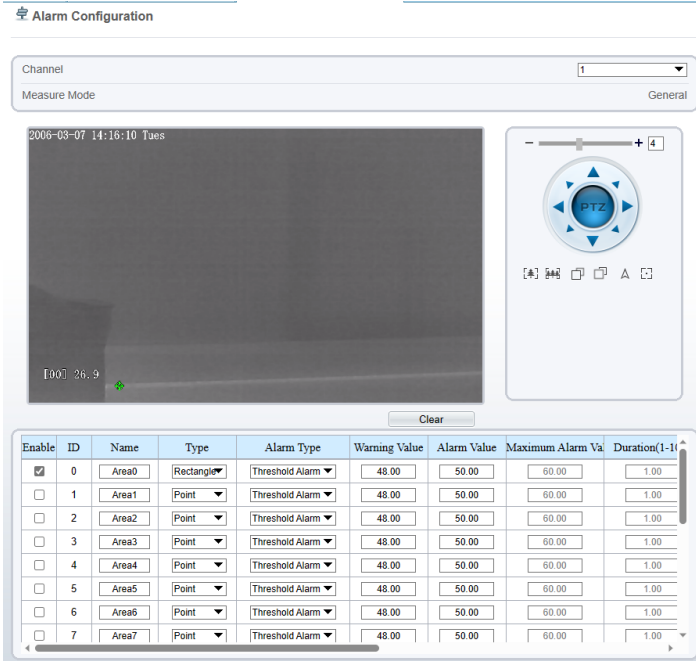

Step 2 Set the parameters according to Table 4-6

Table 4-6 Temperature area and alarm configuration

Parameter	Description	Setting
Channel	N/A	[Setting method] Select a value from the drop-down list box. [Default value] <b>1</b>
Measure Mode	Set at temperature parameter interface.	N/A
Enable	Tick to enable the areas	N/A
ID	It ranges from 0 to 19	N/A

Parameter	Description	Setting
Name	Area name of temperature area.	[Setting method] Enter a value manually.
Type	Type of temperature area. ID 0 is default rectangle area, which is full screen.	[Setting method] Select a value from the drop-down list box. [Default value] <b>Rectangle/Point</b>
Alarm Type	Threshold alarm, Section Alarm and Temperature difference alarm are available for alarm type.	[Setting method] Select a value from the drop-down list box. [Default value] <b>Threshold alarm</b>
Warning Value	Camera will warn when the surveillance object temperature reaches the warning value. At threshold alarm type and difference alarm type can be set.	[Setting method] Enter a value manually. [Default value] <b>48.00</b>
Alarm Value	Camera will alarm when the surveillance object temperature reaches the alarm value.	[Setting method] Enter a value manually. [Default value] <b>50.00</b>
Maximum Alarm Value	At section alarm type, the device would not alarm when the temperature is higher than maximum alarm value.	[Setting method] Enter a value manually. [Default value] <b>60.00</b>
Duration(1-10S)	The time duration of alarm.	[Setting method] Enter a value manually ranges from 1 to 10. [Default value] <b>1</b>
Emission Rate	The emission rate is the capability of an object to emit or absorb energy. The emission rate should be set only when the target is special material. The emission rate list refers to B Common Emission Rate	[Setting method] Enter a value manually. [Default value] <b>0.95</b>

Parameter	Description	Setting
Distance(m)	The distance between camera and target.	[Setting method] Enter a value manually. [Default value] <b>15</b>  <b>NOTE</b> Enter actual distance when the distance between camera and target is less than 15 m. Enter 15 when the distance between camera and target is great than or equal to 15 m.
Reflection	Function Switch, use to control Reflection temperature enable/disable.	[Setting method] Click the box to enable/disable.
Reflection temperature	The function use to adjust thermal radiation effects.	[Setting method] Enter a value manually. [Default value] <b>50</b>
Ignore Object	The target in the detection area will be ignore. The type of target include just person, car, person or car.	[Setting method] Select a value from the drop-down list box. [Default value] <b>None</b>
Alarm	Open or close the alarm output and linkage of area.	[Setting method] Tick the alarm areas
Masking	It will producing a shielded area when the box be selected. It will not display the temperature in the area.	[Setting method] Click the box to enable/disable.

Parameter	Description	Setting
Group ID	Multi region temperature difference alarm: When the difference between the maximum temperature and the average temperature of Multi regions (the average temperature of Multi regions is then averaged) in Multi regions of the same group ID reaches the set warning value/alarm value, an alarm is trigger. That is how Group ID means	[Setting method] Select a value from the drop-down list box. [Default value] <b>None</b>

### Step 3 Set temperature area.

1. Tick an area ID.
2. Select type from Polygon.
3. Click left of mouse button one by one at the video screen, click right of mouse to end the operation, then a detection area will be created, be noticed the detection point must be more than two point, as shown in Figure 4-13. Right-click to finish the area selected.

Figure 4-13 Temperature Area Setting Interface



4. Click **Apply**, the message “Apply success” is displayed, the temperature area is set successfully.

#### Delete a temperature area:

1. Select an area ID.
2. Click the ‘clear’ button, and ensure the ‘enable’ box be unselected.
3. Click **Apply**, the message “Apply success” is displayed, the temperature area is deleted successfully.

### Step 4 Click **Apply**.

The message "Apply success" is displayed, the system saves the settings.

----End

#### 4.1.8.4 Privacy Zone Masking

Privacy Zone Masking is meaning that the camera will not to detect the temperature of that area.

##### Operation Procedure

Step 1 Choose **Configuration > Thermal > Privacy Zone Masking**.

Figure 4-14 Privacy Zone Masking

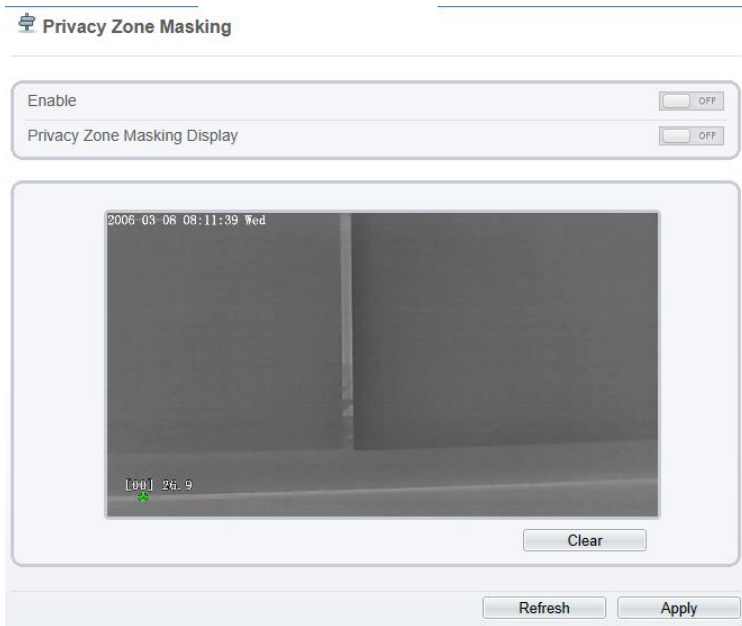

Step 2 Click 'enable' button.

Step 3 Enable the **Privacy Zone Masking Display**, then the Privacy Zone will show on live video.

Step 4 Click left mouse button to set area, click right mouse button to end the setting.

Step 5 Click **Clear** to clear the Privacy Zone Masking.

----End

## 4.1.8.5 Schedule Linkage

### Operation Procedure

#### Step 1 Choose **Configuration > Thermal > Schedule Linkage**

The **Schedule Linkage** page is displayed, as shown in Figure 4-15.

Figure 4-15 Schedule Linkage

**Schedule Linkage**

Threshold Alarm    Threshold Warning    Temperature Differenc    Temperature Differenc    Temperature Section A

Temperature Rise Alar    **Temperature Rise War**

Output Channel 1 2

PTZ Linkage  off

Alarm Record  off

SMTP  off

FTP Upload  off

Audible Alarm  off

Armed     UnArmed

	0	1	2	3	4	5	6	7	8	9	10	11	12	13	14	15	16	17	18	19	20	21	22	23	24
Sun																									
Mon																									
Tues																									
Wed																									
Thur																									
Fri																									
Sat																									

Refresh    Apply

Step 2 Tick the output channel.

Step 3 Enable “PTZ Linkage”, “Alarm Record”, “SMTP”, “FTP”, “Audible Alarm” button.

Step 4 Set schedule linkage.

**Method 1:** Click left mouse button to select any time point within 0:00-24:00 from Monday to Sunday as shown in Figure 4-15.

**Method 2:** Hold down the left mouse button, drag and release mouse to select the alarm time within 0:00-24:00 from Sunday to Saturday.



### NOTE

When you select time by dragging the cursor, the cursor cannot be moved out of the time area. Otherwise, no time can be selected.

**Method 3:** Click  in the alarm time page to select the whole day or whole week.

**Deleting alarm time:** Click  again or inverse selection to delete the selected alarm time.

Step 5 Click **Apply**.

The message "Apply success" is displayed, the system saves the settings.

----End

## 4.1.8.6 Defect Pixel Correction

### Description

The points that can't move when the environment or scenario change is bad point. You can delete the bad point by bad point check function.

### Procedure

Step 1 Choose **Configuration > Thermal > Defect Pixel Correction**

The **Defect Pixel Correction** page is displayed, as shown in Figure 4-16.

Figure 4-16 Defect Pixel Correction

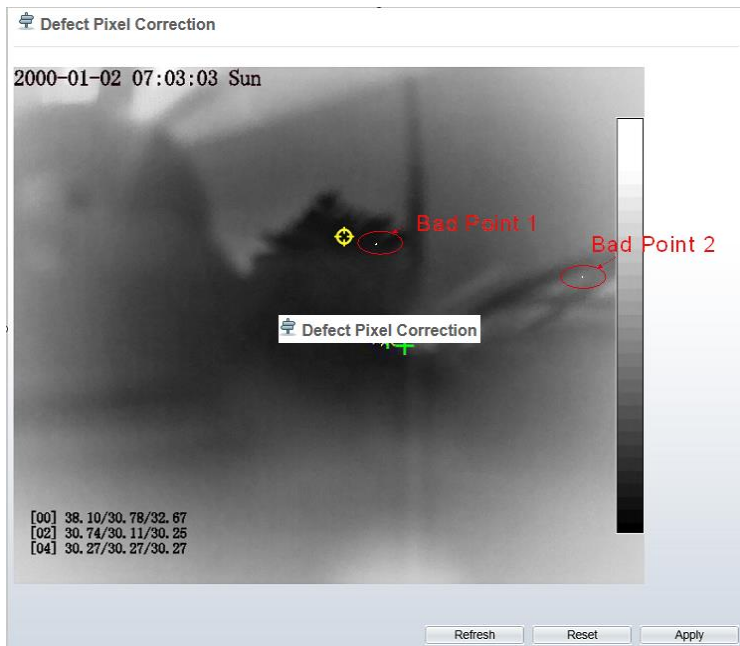



Step 2 Click the white point at image, click **Apply** to recover the pixel, as shown in Figure 4-17

Figure 4-17 Recover pixel



Step 3 Click **Cancel** to return the previous settings.

Step 4 Click **Apply**. The message "Apply success" is displayed, the system saves the settings.

----End

### 4.1.8.7 Version Information

#### Description

It record the MCU(a hardware in device) information, don't support user to setup it.

#### Procedure

Step 1 Choose **Configuration > Thermal > Version Information**

The **Version information** page is displayed, as shown in Figure 4-18.

Figure 4-18 Version Information

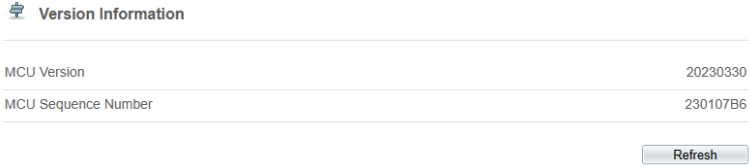

----End

## 4.2 Visible-light Web

### 4.2.1 Login and Logout



#### CAUTION

You must use Edge/Chrome/Firefox to access the web management system; otherwise, some functions may be unavailable.

#### Login system

Step 1 Open Internet Explorer, enter the IP address of the IP camera (default value: 192.168.0.120) in the address box, and press **Enter**.

The login page is displayed, as shown in Figure 4-19.

Figure 4-19 Login page

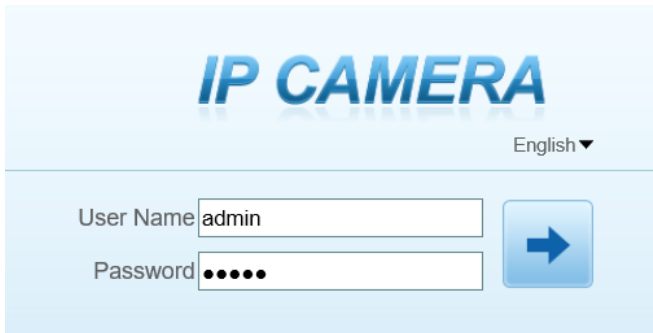

Step 2 Enter the user name, and password.

 **NOTE**

- The default user name is admin. The default password is admin.
- Please change the password to ensure system security.
- You can change the system display language on the login page

Step 3 Click login.

The main page is displayed.

----End

Logout



To log out of the system, click  in the upper right corner of the main page. The login page is displayed after you log out of the system.

## 4.2.2 Main Page Layout

On the main page, you can view Live videos, receive alarm and fault notifications, set parameters, change the password, and log out of the system. Figure 4-20 shows the main page layout. Table 4-7 describes the elements on the main page.

Figure 4-20 Main page layout

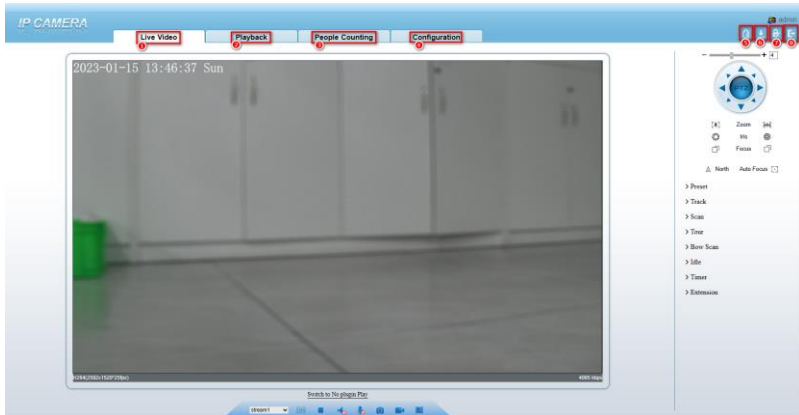





Table 4-7 Elements on the main page

No.	Element	Description
1	Live video area	Live videos are played in this area. You can also set sensor parameters.

No.	Element	Description
2	Playback	You can query the playback videos in this area. NOTE Only when the SD have videos that you can query the playback videos.
3	People Counting	You can query graph data about the number of people if the statistical function has been configured and statistical data is available.
4	Configuration	You can choose a menu to set device parameters, including the device information, audio and video streams, alarm setting, and privacy mask function.
5	Plugins of IP camera LocalServer	You can click  to download the plugins. If you use the device web page too frequencies. Suggest you Install the plugins first.
6	Backup Status	The icon  display the record video backup status. It display backup list and completion degree while you click the icon in non plug-in. And just display backup status in plug-in model.
7	Change password	You can click  to change the password.
8	Sign Out	You can click  to return to the login page.

----End

### 4.2.3 Change the Password

#### Description

You can click  to change the password for logging in to the system.

#### Procedure

Step 1 Click  in the upper right corner of the main page.

The **Change Password** dialog box is displayed, as shown in Figure 4-21.

Figure 4-21 Modify Password dialog box

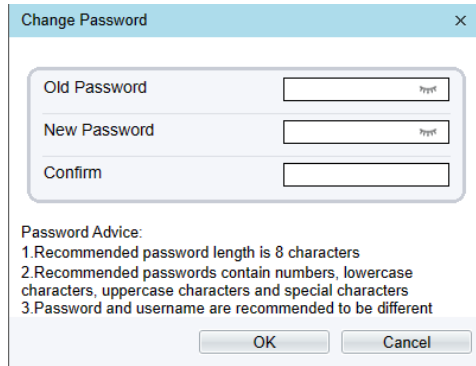

 **NOTE**

The change password page will be displayed if you don't change the default password when you login the system for the first time. User need to wait at least three minutes after changing password, and then restart the device. The password incorrect more than 3 times, please login again after 5 minutes Enter the old password, new password, and confirmation password.

Step 2 Click **OK**.

If the message "Change password success" is displayed, the password is successfully changed. If the password fails to be changed, the cause is displayed. (For example, the new password length could not be less than eight.)

Step 3 Click **OK**.

The login page is displayed.

----**End**

## 4.2.4 Browse Video

User can browse the Live video in the web page. And you had better use the web like Edge/Chrome web application.

### Preparation

There are two methods to play Live video, no-plugins and plugins. If you login web page use Edge application, the Live video be played by no-plugins method. This method requires high hardware performance for computer graphics cards.

So we suggest to ensure the Live video can be play properly, you had better perform install plugins in your computer, please following operation below :

Step 1 Open the Edge, login the web page. Click plugins  icon to download IP camera local Server plugins. The web page will pop up tip box after the download task finished, as shown in Figure 4-4

Figure 4-22 Tip download box



Step 2 Click icon , it will pop up an operation options, click the title keep, then click keep away after the confirm box pop up, as show in Figure 4-5.

Figure 4-23 download plugins



Step 3 Then the IPCLocalServer.exe plugins download successful.

### 4.2.5 Install Plugins

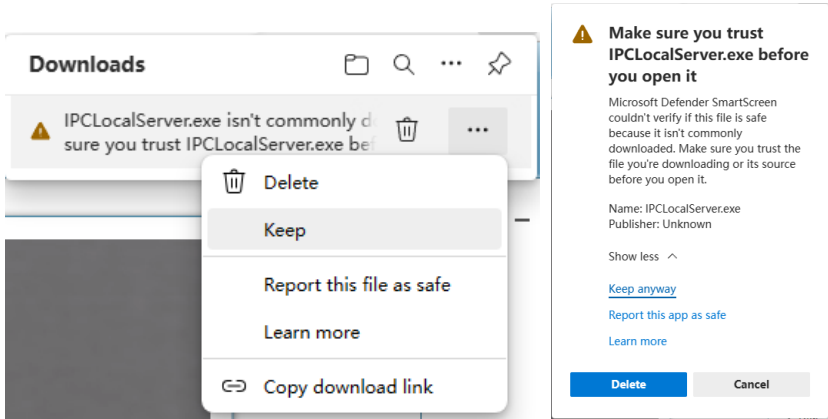
You download the plugins before, then we need to install the plugins. Click open file or double click the IPCLocalServer.exe as shown in Figure 4-6 to start install process.

Figure 4-24 Download the plugin page



Step 2 It will pop up install box to help user to install plugins, you just need to click twice 'next' button , once 'install' button, once 'finish' button to finish the installation.

Step 3 Reopen or refresh the browser after installation, the plugins is going working.

----End

## 4.2.6 Set Local Network Parameters

### Description

Local network parameters include:

- IP protocol
- IP address
- Subnet mask
- Default gateway
- Dynamic Host Configuration Protocol (DHCP)
- Preferred Domain Name System (DNS) server
- Alternate DNS server
- MTU

### Procedure

Step 1 Choose **Configuration > Device > Local Network**..

The **Local Network** page is displayed, as shown in Figure 4-25

Figure 4-25 Local Network page

**Local Network**

Network Card ID	1
IP Protocol	IPv4

**DHCP**  OFF

IP Address	192.168.32.151
Subnet Mask	255.255.255.0
Default Gateway	192.168.32.1

Preferred DNS Server	202.96.128.86
Alternate DNS Server	202.96.134.133
MTU(800-1500)	1500

Step 2 Set the parameters according to Table 4-8.

Table 4-8 Local network parameters

Parameter	Description	Setting
IP Protocol	IPv4 is the IP protocol that uses an address length of 32 bits.	[Setting method] Select a value from the drop-down list box. [Default value] <b>IPv4</b>
Obtain IP address automatically	The device automatically obtains the IP address from the DHCP server.	[Setting method] Click the button on to enable <b>DHCP</b> . NOTE To query the current IP address of the device, you must query it on the platform based on the device name.
DHCP IP	IP address that the DHCP server assigned to the device.	N/A
IP Address	Device IP address that can be set as required.	[Setting method] Enter a value manually. [Default value] <b>192.168.0.120</b>
Subnet Mask	Subnet mask of the network adapter.	[Setting method] Enter a value manually. [Default value] <b>255.255.255.0</b>
Default Gateway	This parameter must be set if the client accesses the device through a gateway.	[Setting method] Enter a value manually. [Default value] <b>192.168.0.1</b>
Preferred DNS Server	IP address of a DNS server.	[Setting method] Enter a value manually. [Default value] <b>192.168.0.1</b>



Parameter	Description	Setting
Alternate DNS Server	IP address of a domain server. If the preferred DNS server is faulty, the device uses the alternate DNS server to resolve domain names.	[Setting method] Enter a value manually. [Default value] <b>192.168.0.2</b>
MTU(800-1500)	Set the maximum value of network transmission data packets.	[Setting method] Enter a value manually. NOTE The MTU value is range from 800 to 1500, the default value is 1500, Please do not change it arbitrarily.

### Step 3 Click **Apply**.

- If the message "Apply succeed!" is displayed, click Confirm. The system saves the settings. The message "Set network parameter success, Please login system again" is displayed. Use the new IP address to login to the web management system.
- If the message "Invalid IP Address", "Invalid Subnet Mask", "Invalid default gateway", "Invalid primary DNS", or "Invalid space DNS" is displayed, set the parameters correctly.

**----End**

# 5 Thermal Image Settings

## 5.1 Access the Image Settings Interface

Operation procedure:

Step 1 When you login web page. Choose **Configuration > Image Settings**. Then the Image Settings display, as show in Figure 5-1

Figure 5-1 Image Settings interface

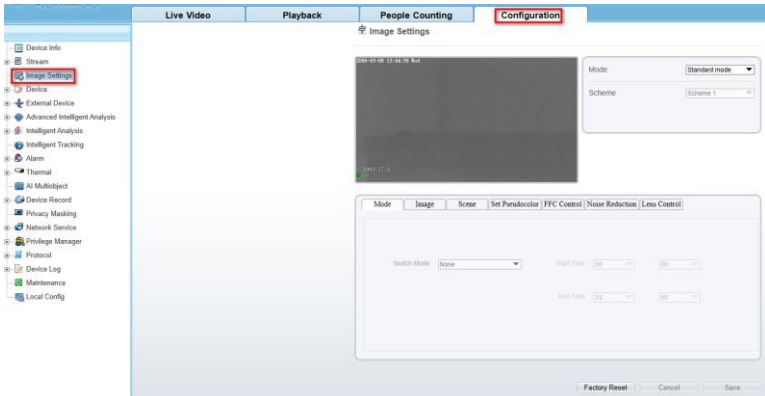

Step 2 Choose the mode is Debug Mode to open image settings dialog box. Then you can adjust image parameter follow your requirement, as show in Figure 5-2

Figure 5-2 Debug Image Settings interface

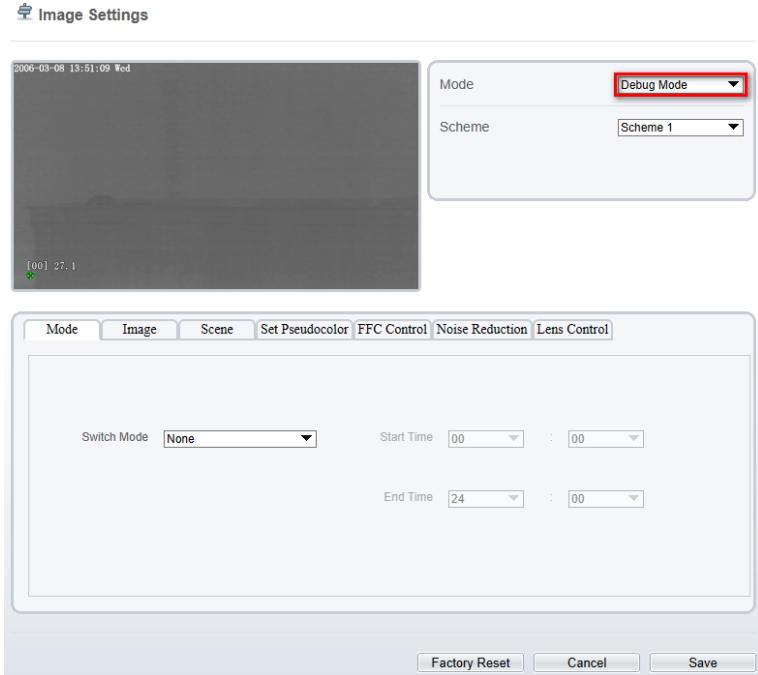

----End

## 5.2 Image Settings Parameter description

### 5.2.1 Mode

Operation procedure:

- Step 1 Click **Mode** tag on Image Settings interface, the Mode page is displayed, as shown in Figure 5-3.

Figure 5-3 Mode page

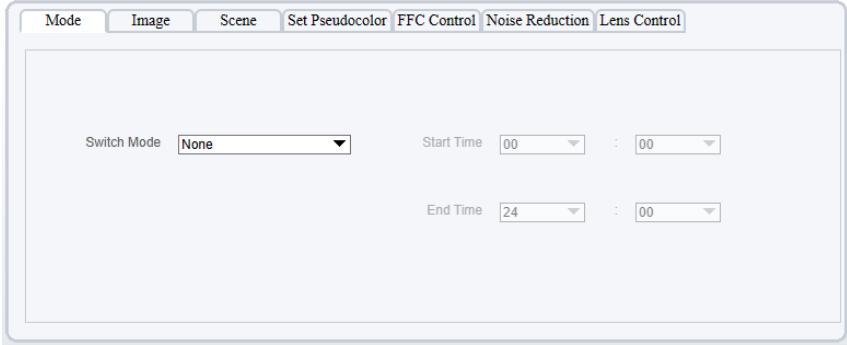

- Step 2 Set the Mode parameters.
- Step 3 Click save to save the setting.
- End**

### 5.2.2 Image

Figure 5-4 shows the image interface.

Figure 5-4 Image interface

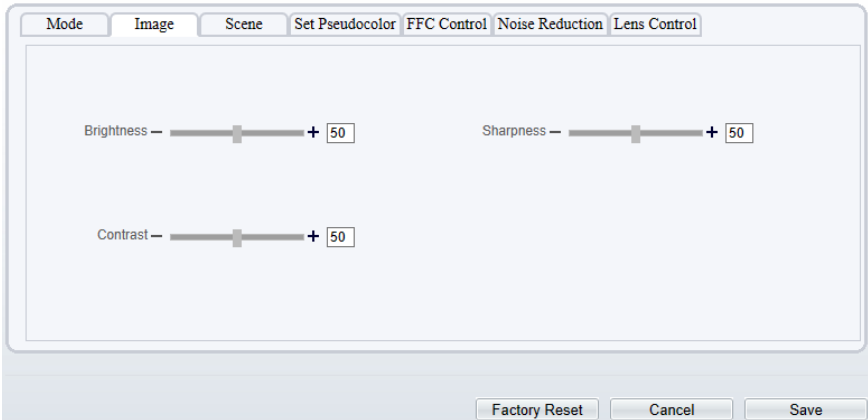

Table 5-1 describes the image setting parameters.

Table 5-1 Image setting parameter description

Parameter	Description	Setting
Brightness	It indicates the total brightness of an image. As the value increases, the image becomes brighter.	[Setting method]

Parameter	Description	Setting
		Drag the slider. [Default value] <b>50</b>
Contrast	It indicates the contrast between the bright part and the dark part of an image. As the value increases, the contrast increases.	[Setting method] Drag the slider. [Default value] <b>50</b>
Sharpness	It indicates the sharpness of the image plane and the sharpness of the image edge. The shaper the image, the better detail contrast.	[Setting method] Drag the slider. [Default value] <b>50</b>

----End

### 5.2.3 Scene

Figure 5-5 shows the scene interface.

Figure 5-5 Scene interface

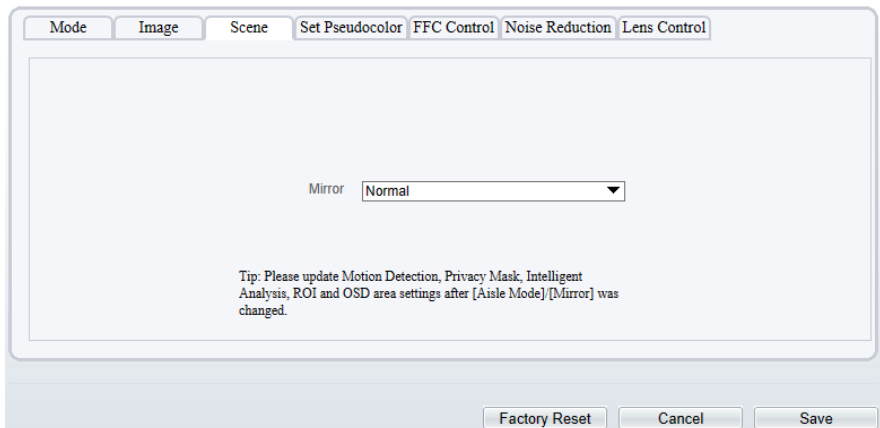

Provide the selection of image pixel locations.

Normal: the image is not flipped.

Horizontal: the image is flipped left and right.

Vertical: the image is flipped up and down.

Horizontal + Vertical: the image upside-down and reversal.

## 5.2.4 Set Pseudocolor

Figure 5-6 shows the Set Pseudocolor interface.

Figure 5-6 Set Pseudocolor interface

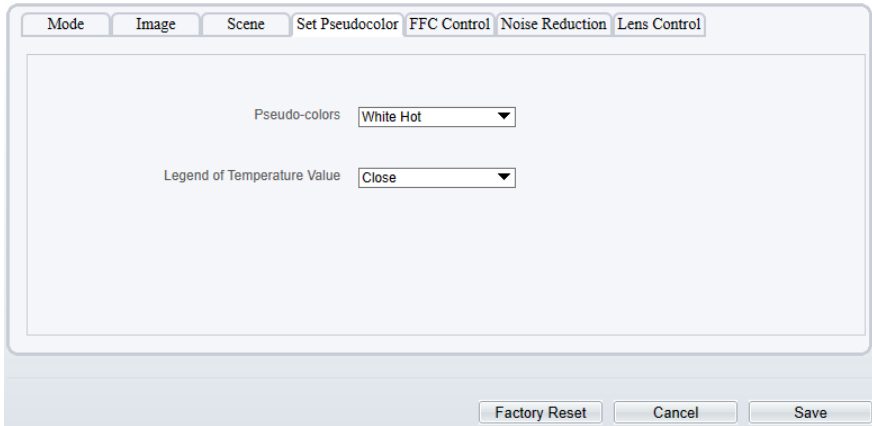

Polarity/LUT: the temperatures of the temperature fields detected by the thermal imaging camera are separately mapped to values ranging from 0 to 255 by the algorithm. In the black/white display mode, this range is converted to the grayscale tones. For example, 0 indicates completely black, and 255 indicates completely white. The temperature field of the scene is converted to images by using the grayscale ranging from 0 to 255. Different polarity modes can be converted to different display images. The most common setting is white hot (a hotter object is displayed brighter than a colder object) or black hot (a hotter object is displayed darker than a colder object). The difference between two modes lies in that the temperatures corresponding to the darker one and the lighter one are reversed. Other modes include rainbow, ironbow, HSV, autumn, bone and so on.

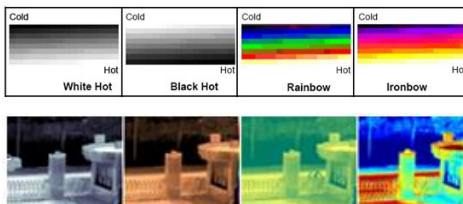

**Temperature strip switch** is on, the live video will show it, otherwise is no strip.

## 5.2.5 FFC Control

Figure 5-7 shows the FFC interface.

Figure 5-7 FFC interface

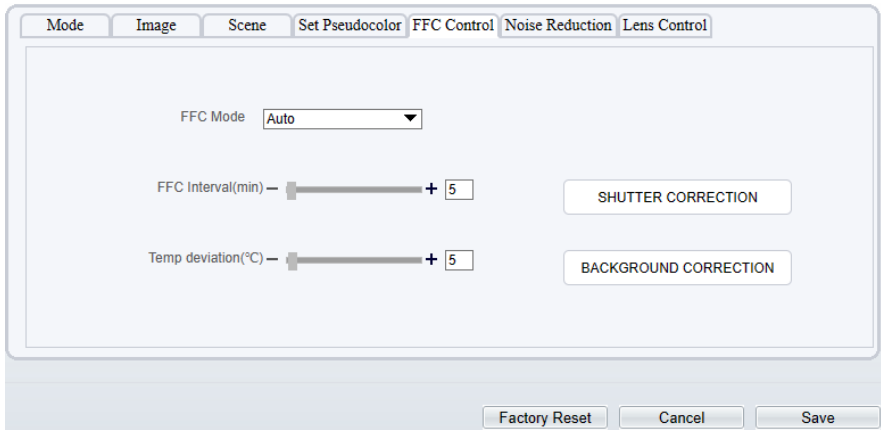

Table 5-2 describes the FFC mode parameters.

Table 5-2 FFC control parameter description

Parameter	Description	Setting
FFC Mode	The internal of the thermal imaging camera may comprise the mechanical action correction mechanism that can periodically improve the image quality. This component is called flat field correction (FFC). When controlling the FFC, the FFC shields the sensor array, so that each portion of the sensor can collect uniform temperature fields (flat field). By means of FFC, the camera can update the correction coefficients to output more uniform images. Throughout the FFC process, the video image is frozen for two seconds and a static-frame image is displayed. After the FFC is complete, the image is automatically recovered. Repeated FFC operations can prevent the grainy and image degradation problems. The FFC is especially important when the temperature of the camera changes. For example, after the camera is powered on or the ambient temperature is changed, you should immediately perform the FFC.	[How to set] Select from the drop-down list box. [Default value] <b>Auto</b>

Parameter	Description	Setting
	<p><b>Auto:</b> In the Automatic FFC mode, the camera performs FFC whenever its temperature changes by a specified amount or at the end of a specified period of time (whichever comes first). When this mode is selected, the FFC interval (minutes) ranges from 5 to 30 minutes. The temperature change of the camera is based on the temperatures collected by the internal temperature probe. The temperature of the camera sharply changes when the camera is powered on. The FFC is relatively frequent, which is normal.</p> <p><b>Manual:</b> In the manual FFC mode, the camera does not automatically perform the FFC based on the temperature change or the specified period. You can press the Do FFC button to select the manual FFC mode. When you feel that the image is obviously degraded but the automatic FFC is not performed, you can use the manual FFC function to check whether the image quality can be improved.</p>	
FFC Interval (min)	In the automatic FFC mode, the FFC interval ranges from 5 to 255 minutes.	[How to set] Drag the slider. [Default value] <b>5</b>
Temper Interval	In the automatic FFC mode, the FFC interval ranges from 5 to 25.5 centigrade.	[How to set] Drag the slider. [Default value] <b>5</b>
SHUTTER CORRECTION	Click the icon to adjust exposure immediately.	N/A
BACKGROUND CORRECTION	Click the icon and cover the camera with something to adjust image. Remove the thing to finish adjustment.	N/A

----End

## 5.2.6 Noise Reduction

Figure 5-8 shows the Noise Reduction interface.



Figure 5-8 Noise Reduction interface

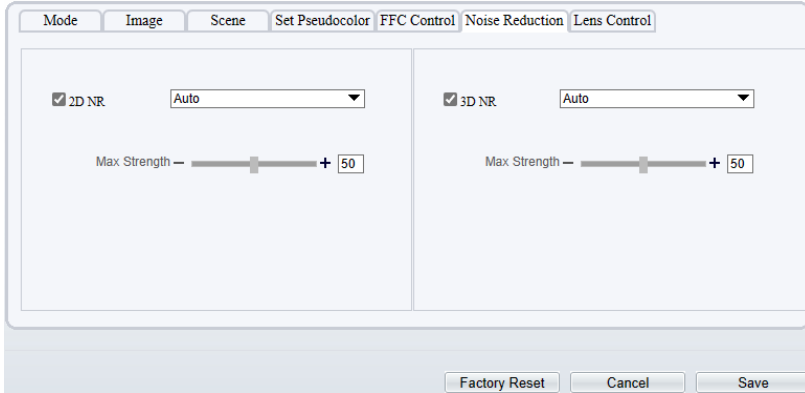

Table 5-3 describes noise reduction parameters.

Table 5-3 DNR parameter description

Parameter	Description	Setting
2 DNR	Decrease the image noise.	[How to set] Select from the drop-down list box. Drag the slider to adjust max strength. [Default value] <b>Auto</b>
3 DNR	Decrease the image noise.	[How to set] Select from the drop-down list box. Drag the slider to adjust max strength. [Default value] <b>Auto</b>

----End

# 6 Visible-light Parameter Configuration

## 6.1 Access the Image Settings Interface

Operation procedure:

Step 1 When you login web page. Choose **Configuration > Image Settings**. Then the Image Settings display, as show in Figure 6-1

Figure 6-1 Image Settings interface

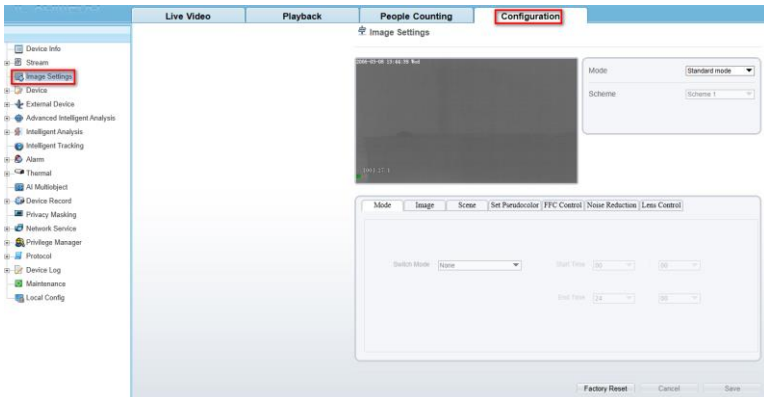

Step 2 Choose the mode is Debug Mode to open image settings dialog box. Then you can adjust image parameter follow your requirement, as show in Figure 6-2

Figure 6-2 Debug Image Settings interface

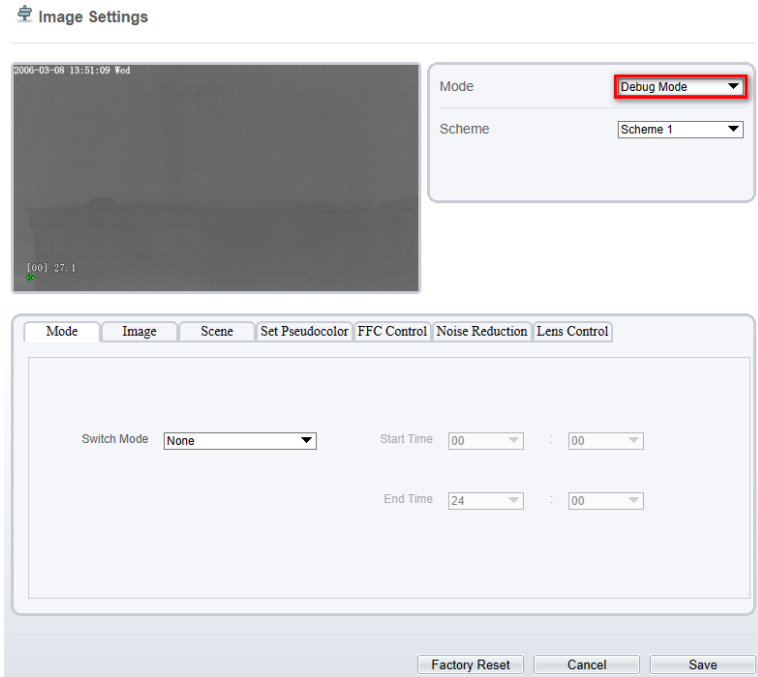

----End

## 6.2 Sensor Setting Parameter description

### 6.2.1 Mode

Operation procedure:

- Step 1 Click **Mode** tag on Image Settings interface, the Mode page is displayed, as shown in Figure 6-3.

Figure 6-3 Mode page

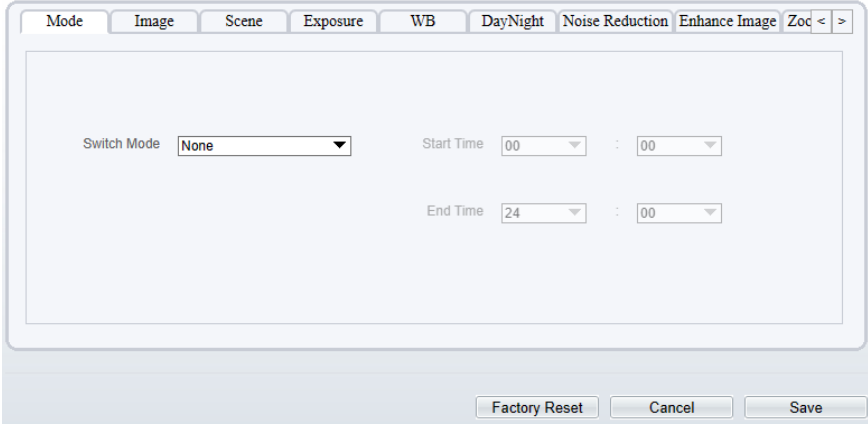

- Step 2 Set the Mode parameters.
  - Step 3 Click save to save the setting.
- End

### 6.2.2 Image

Figure 6-4 shows the Image interface.

Figure 6-4 Image interface

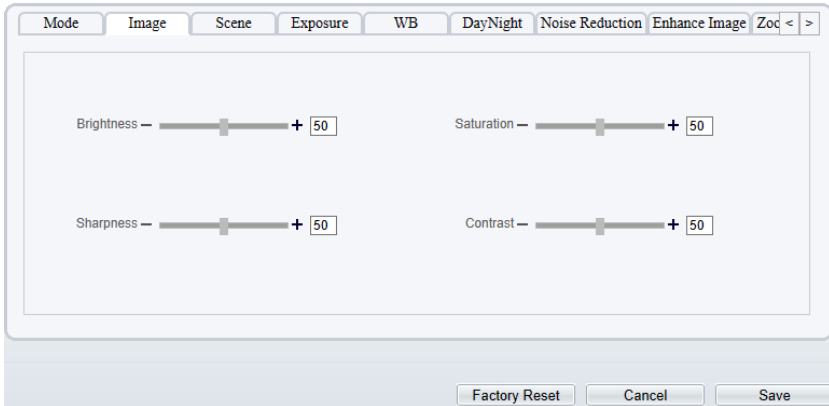

Table 6-1 describes the parameters on the Image interface.

Table 6-1 Parameters on the Image interface

Parameter	Description	Configuration Method
Contrast	It indicates the contrast between the bright part and the dark part of an image. As the value increases, the contrast increases.	[Setting method] Drag the slider. [Default value] <b>50</b>
Brightness	It indicates the total brightness of an image. As the value increases, then image becomes brighter.	[Setting method] Drag the slider. [Default value] <b>50</b>
Sharpness	It indicates the border sharpness of an image. As the value increases, the borders become clearer, and the number of noise points increases.	[Setting method] Drag the slider. [Default value] <b>50</b>
Saturation	It indicates the color saturation of an image. As the value increases, the image becomes more colorful.	[Setting method] Drag the slider. [Default value] <b>50</b>

----End

## 6.2.3 Scene

Figure 6-5 shows the scene interface.

Figure 6-5 Scene interface

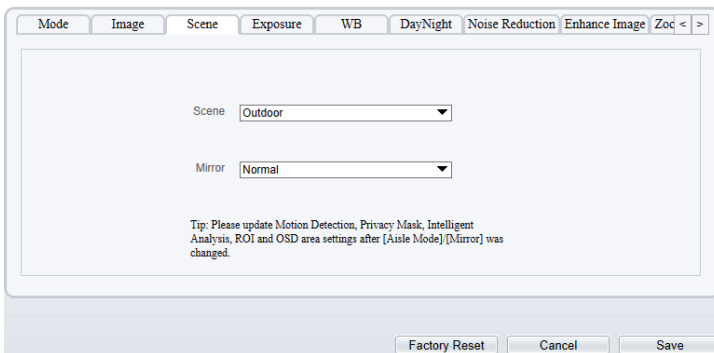

Table 6-2 describes the Scene parameters.

Table 6-2 Scene description

Parameter	Description	Configuration Method
<b>Scene</b>	<p>It indicates the working mode of a camera.</p> <ul style="list-style-type: none"> <li>Outdoor: It applies to outdoor scenarios.</li> <li>Indoor: It applies to indoor scenarios.</li> </ul>	<p>[Configuration method] Select from the drop-down list [Default value] <b>Outdoor</b></p>
<b>Mirror</b>	<p>It is used to select the pixel location of an image.</p> <ul style="list-style-type: none"> <li>Normal: The image does not flip.</li> <li>Horizontal: The image flips to the left and right.</li> <li>Vertical: The image flips up and down.</li> <li>Horizontal and vertical: The image rotates at 180 degrees.</li> </ul>	<p>[Setting method] Select a value from the drop-down list. [Default value] <b>Normal</b></p>

## 6.2.4 Exposure

Figure 6-6 shows the Exposure interface.

Figure 6-6 Exposure interface

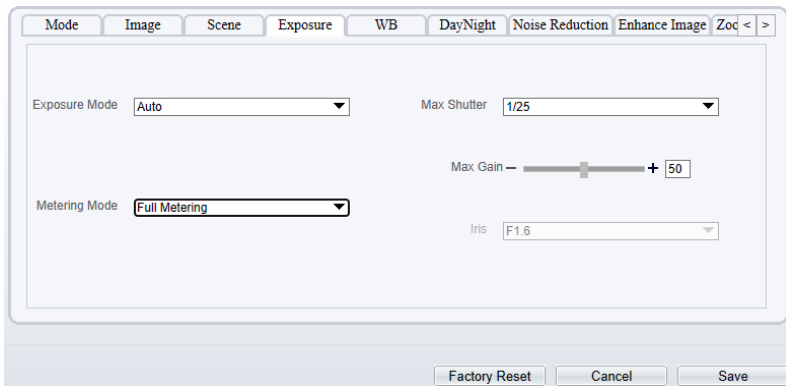

Table 6-3 describes Exposure parameters.

Table 6-3 Exposure parameters description

Parameter	Meaning	Configuration Method
<b>Exposure Mode</b>	<p>The exposure modes include:</p> <ul style="list-style-type: none"> <li>• <b>Auto:</b> The system performs auto exposure based on the monitoring environment.</li> <li>• <b>Manual:</b> You can adjust the brightness of an image by setting the following three items: <b>Shutter Setting, Iris Setting and Gain Setting.</b></li> <li>• <b>Shutter Priority:</b> You can set <b>Shutter Setting</b> to fixed values. The iris and gain are automatically adjusted by the system.</li> <li>• <b>Iris Priority (for high speed dome):</b> You can set Iris Setting to fixed values. The shutter and gain are automatically adjusted by the system.</li> </ul>	<p>[Setting method] Select a value from the drop-down list. [Default value] <b>Auto</b></p>
<b>Metering Mode</b>	<p>The device Metering area. There are three mode for user to setup.</p>	<p>[Setting method] Select a value from the drop-down list. [Default value] <b>Auto</b></p>
<b>Max Shutter</b>	<p>The device automatically adjusts the shutter time based on the ambient brightness. The shutter time is less than or equal to the value of this parameter.</p>	<p>[Setting method] Select a value from the drop-down list. [Default value] <b>1/25</b></p>
<b>Max Gain</b>	<p>The device automatically adjusts the gain based on the external light. The gain is less than or equal to the value of this parameter.</p>	<p>[Setting method] Drag the slider. [Default value] <b>50</b></p>

### 6.2.5 WB Setting

Figure 6-7 shows the **WB Setting** interface.

Figure 6-7 WB interface

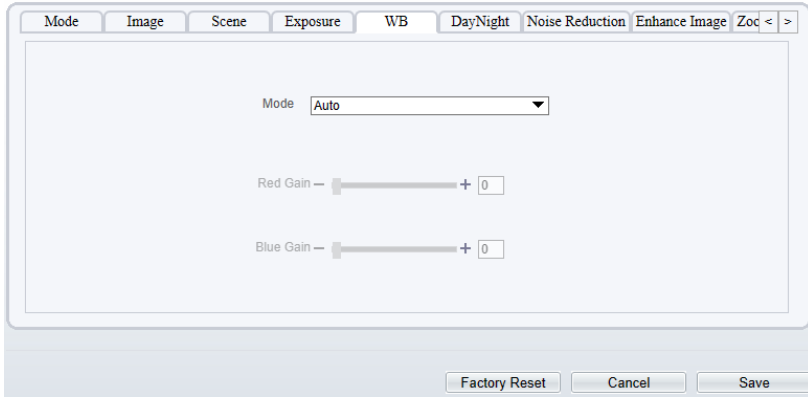



Table 6-4 describes **WB Setting** parameters.

Table 6-4 **WB Setting** parameters description

Parameter	Meaning	Configuration Method
<b>Mode</b>	<p>It is adjusted based on application scenarios to improve the fidelity of the image color. The WB modes include:</p> <ul style="list-style-type: none"> <li>• <b>Auto</b>: In automatic white balance (WB) mode, the system automatically performs white balance based on the monitoring environment.</li> <li>• <b>Tungsten</b></li> <li>• <b>Daylight</b></li> <li>• <b>Manual</b>: In manual WB mode, you can manually select a WB mode based on the monitoring environment.</li> </ul>	<p>[Setting method] Select a value from the drop-down list. [Default value] <b>Auto</b></p>
<b>Red Gain</b>	<p>It indicates the gain applied to red channels. As the value increases, the color temperature becomes lower.</p> <p> <b>NOTE</b> This parameter is valid when <b>Manual Mode</b> is set to <b>Customized</b>.</p>	<p>[Setting method] Drag the slider. [Default value] <b>0</b></p>



Parameter	Meaning	Configuration Method
<b>Blue Gain</b>	<p>It indicates the gain applied to blue channels. As the value increases, the color temperature becomes higher.</p> <p> <b>NOTE</b></p> <p>This parameter is valid when <b>Manual Mode</b> is set to <b>Customized</b>.</p>	<p>[Setting method]                      Drag the slider.                      [Default value]  <b>0</b></p>

## 6.2.6 Daynight

The day night mode settings vary based on device models. For details, see the following sections.

Figure 6-8 shows the **DayNight Mode** interface.

Figure 6-8 DayNight Mode interface

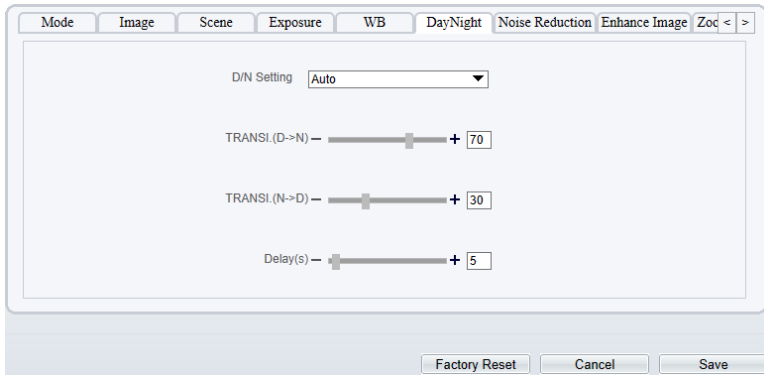





Table 6-5 describes **DayNight Mode** parameters.

Table 6-5 DayNight parameters description

Parameter	Meaning	Configuration Method
<b>D/N Setting Mode</b>	<p>It can be set to <b>Auto, Day, Night</b> or <b>Timing</b>.</p> <ul style="list-style-type: none"> <li>• <b>Auto mode</b> The image color and filter status are automatically switched based on the ambient brightness. The filter prevents infrared light from entering the sensor in the day state and allows all types of light to enter the sensor in the night state.</li> <li>• <b>Day mode</b> The image is colored, and the filter is in the day state, preventing infrared light from entering the sensor.</li> <li>• <b>Night mode</b> The image is black and white, and the filter is in the night state, allowing infrared light to enter the sensor.</li> <li>• <b>Timing</b> Set day to night time and night to day time to switch the daynight mode.</li> </ul>	<p>[Setting method] Select a value from the drop-down list. [Default value] <b>Auto</b></p>
<b>TRANSL.(D-&gt;N)(dB)</b>	<p>It determines the day-to-night switching in auto mode. When the system gain is greater than the value of this parameter, the system enters the night mode.</p> <p> <b>NOTE</b> This parameter is valid in auto mode. The value of <b>TRANSL.(D-&gt;N)</b> must be greater than the value of <b>TRANSL.(N-&gt;D)</b>.</p>	<p>[Setting method] Drag the slider. [Default value] <b>70</b></p>

Parameter	Meaning	Configuration Method
<b>TRANSL.(N-&gt;D)(dB)</b>	<p>It determines the night-to-day switching in auto mode. When the system gain is smaller than the value of this parameter, the system enters the day mode.</p> <p> <b>NOTE</b> This parameter is valid in auto mode. The value of <b>TRANSL.(D-&gt;N)</b> must be greater than the value of <b>TRANSL.(N-&gt;D)</b>.</p>	<p>[Setting method] Drag the slider. [Default value] <b>30</b></p>
<b>Delay(s)</b>	<p>The delay time of day to night or night to day.</p> <p> <b>NOTE</b> This parameter is valid in auto mode.</p>	<p>[Setting method] Drag the slider. [Default value] <b>0</b></p>
<b>DTN Time</b>	Time of day to night.	<p>[Setting method] Select a value from the drop-down list. [Default value] <b>18:00</b></p>
<b>NTD Time</b>	Time of night to day.	<p>[Setting method] Select a value from the drop-down list. [Default value] <b>6:00</b></p>

## 6.2.7 Noise Reduction

Figure 6-9 shows the Noise Reduction interface.

Figure 6-9 Noise Reduction interface

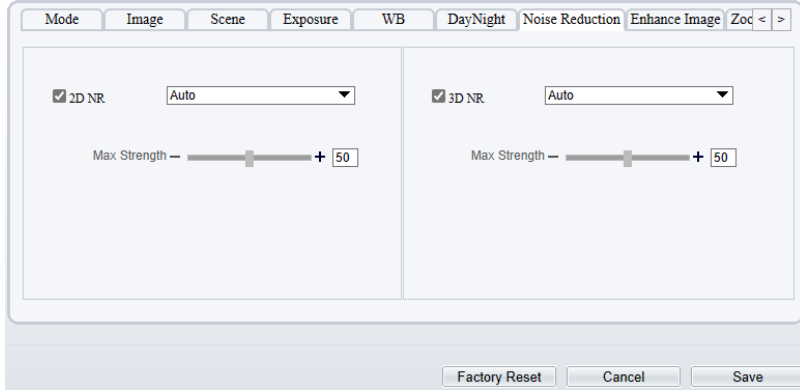

Table 6-6 Noise Reduction parameters.

Table 6-6 Noise Reduction parameters description

Parameter	Meaning	Configuration Method
2D NR	Reduce noise of image.	[Configuration method] Select from the drop-down list [Default value] <b>Auto</b>
3D NR	Reduce noise of image.	[Configuration method] Select from the drop-down list [Default value] <b>Auto</b>
Max Strength	It is valid in auto noise filter mode. When the parameter value is 0, the noise filter is disabled. When the parameter value is greater than 0, the noise filter is enabled, and the system automatically adjusts the noise filter level based on the ambient brightness without exceeding the value of this parameter.	[Setting method] Drag the slider. [Default value] <b>50</b>

## 6.2.8 Enhance Image

Figure 6-10 shows the Enhance Image interface and Table 6-7 shows the Enhance Image parameter.

Figure 6-10 Enhance Image interface

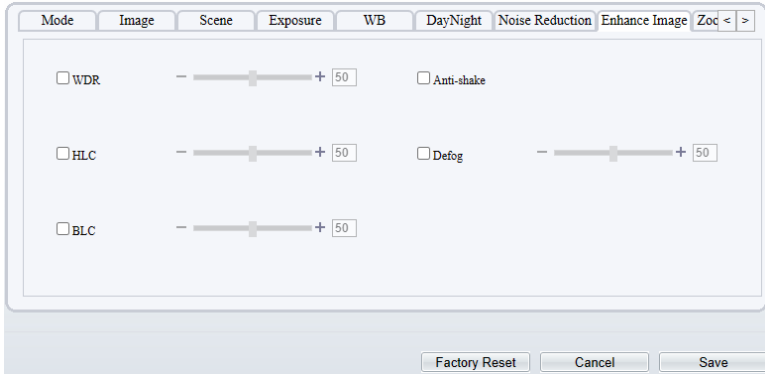

Table 6-7 Enhance Image parameters description

Parameter	Meaning	Configuration Method
WDR	It is used to display the foreground and background at the same time in the environment with a large brightness difference. When the brightness difference is larger, you can increase the WDR level to obtain better image effect.	[Setting method] Tick the WDR mode and drag the slider. [Default value] <b>50</b>
HLC	It provides a clearer view of an image in the highlight environment. When HLC is enabled, the total brightness of an image is reduced, allowing you to view objects in front of the highlight.	[Setting method] Tick the HLC mode and drag the slider. [Default value] <b>50</b>
BLC	It provides a clearer view of an image in the backlight environment. When BLC is enabled, the total brightness of an image increases, allowing you to view objects in front of the backlight. Meanwhile, the objects behind the backlight are exposed excessively.	[Setting method] Tick the BLC mode.
Anti-shake	A function is used to prevent video image shake. The size of picture will be cropped and reduced when the Anti-shake box be selected.	[Setting method] Tick the box to enable.

Parameter	Meaning	Configuration Method
DeFog	It provides a clearer view of an image in the fogged environment when Defog is enabled. As the value increases, the image becomes clearer.	[Setting method] Tick the Defog mode and drag the slider. [Default value] <b>50</b>

## 6.2.9 Zoom Focus

Figure 6-11 shows the zoom focus interface and Table 6-8 shows the zoom focus parameter.

Figure 6-11 Zoom focus interface for high speed dome

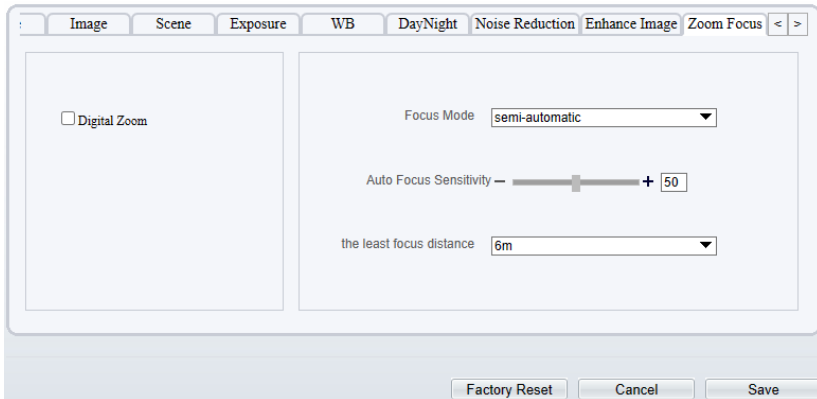



Table 6-8 Zoom focus parameters description

Parameter	Meaning	Configuration Method
Digital Zoom	This function enables digital zoom after an image is zoomed in by 20 times in optical mode.	[Setting method] Tick the Digital.

Parameter	Meaning	Configuration Method
Focus Mode	<p>It can be set to the auto, manual or semi-automatic mode.</p> <p>Auto focus mode: The system automatically triggers focus based on application scenarios.</p> <p>Manual focus mode: You can trigger focus by using the buttons on the client.</p> <p>Semi-automatic focus mode: The system only automatically trigger focus once when the PTZ move or zoom in a scene.</p>	<p>[Configuration method]</p> <p>Select from the drop-down list</p> <p>[Default value]</p> <p><b>Semi-automatic</b></p>
Auto Focus Sensitivity	<p>It indicates the sensitivity of auto focus. When the sensitivity is high, the camera movement is more likely to focus again at slight changes of an image.</p>	<p>[Setting method]</p> <p>Drag the slider.</p> <p>[Default value]</p> <p><b>50</b></p>
The least focus distance	<p>It indicates the minimum focus distance. A camera does not focus when the distance is smaller than this value. For example, if the minimum focus distance is set to 1.5 m, a camera focuses only on objects more than 1.5 m away, and the changes of objects less than 1.5 m away do not affect the focusing.</p> <p> <b>NOTE</b></p> <p>This parameter applies only to visible light.</p>	<p>[Configuration method]</p> <p>Select from the drop-down list</p> <p>[Default value]</p> <p><b>6 m</b></p>

----End

# 7 PTZ Function Application

## 7.1 PTZ Control function

### Operation Description

PTZ Control function is only available to a camera with an external PTZ and High Speed Dome with PTZ function.

### PTZ Control

When browsing Live videos shot by a dome camera or a camera connected to an external PTZ, you can control the PTZ to view Video shot in different directions.

In the PTZ control area, you can click the eight arrow keys to move the PTZ in eight directions, as shown in Figure 7-1.

Figure 7-1 PTZ Control zone



It may also control the iris, zoom and focus of the camera lens through other buttons in the PTZ control zone. Functions of each button are as shown in Table 7-1.



Table 7-1 Descriptions of PTZ buttons

Button	Description
Zoom	Click  or  to adjust the surveillance range of the front-end lens.
Iris	Click  or  to adjust the size of the front-end iris.
Focus	Click  or  to adjust the focus of the front-end lens.
Speed	Drag the slider on  to adjust the rotational speed of the PTZ.
North	Indicates that the direction of the camera is north when user click  North.
Auto Focus	Lens will focus automatic once when you click it.

----End

## 7.2 PTZ configuration

### 7.2.1 PTZ setting

The PTZ configuration interface displayed in Live Video page, under the part of PTZ control, as shown in Figure 7-2.

Figure 7-2 PTZ Configuration

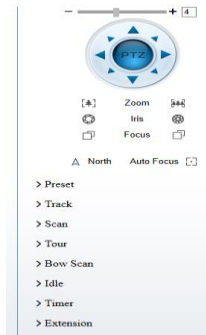

Through this interface, you can perform the following operations:

- Add, Delete and Apply a Preset, Track, Scan, Tour, Bow Scan.
- Set and enable Idle.
- Set the direction to due north.
- Any direction can be set as the reference due north.

- Configure Timer.

----End

## 7.2.2 Configure and Apply Preset



You can configure preset positions and quickly rotate the camera to preset position by applying the preset.

### Operation procedure

- Step 1 Click Expand Arrow Down at **Preset** in the PTZ configuration area, the add preset list is displayed, as shown in Figure 7-3.

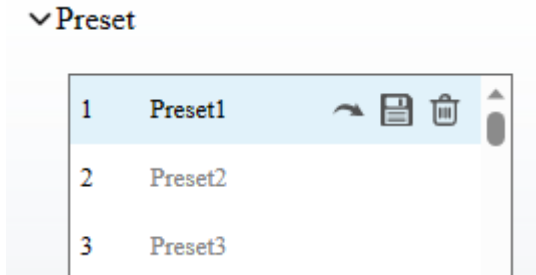
Figure 7-3 Preset configuration



- Step 2 Operate your PTZ to the position you want, then click save icon , the preset be created.
- Step 3 Choose the preset you created, and click the preset name, you can modify the preset name. Please remember save it after you changed.
- Step 4 If you want to delete a preset, move your mouse to the preset you want to delete, and click delete icon , the preset be deleted. There are no tips for your delete operation, so be careful to do this.

### NOTE

Up to 255 Presets can be configured

----End

## 7.2.3 Configure and Apply Tracks

You can record a track to allow the camera to repeatedly rotate based on the preset track.



## Operation procedure

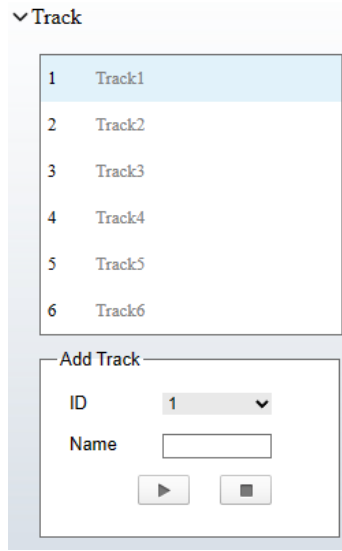

Step 1 Click Expand Arrow Down at Track in the PTZ configuration area, the add track page is displayed as shown in Figure 7-4.

Figure 7-4 Add Track



Step 2 Select a track ID from the Add Track box, enter the track name.

Step 3 Click , then use eight arrow keys in the **PTZ control** area to configure a track, then click  to complete adding a track.

Step 4 Select the track name from the Track list and click  to apply the track. If you want to delete the track, move your mouse to the track you want to delete, and click delete icon , the track be deleted.

### NOTE

Up to 6 Tracks can be configured.

Track name not support to modify.

----End

## 7.2.4 Configure and Apply Scan



You can configure a Scan to rotate the camera between two positions by applying the Scan.

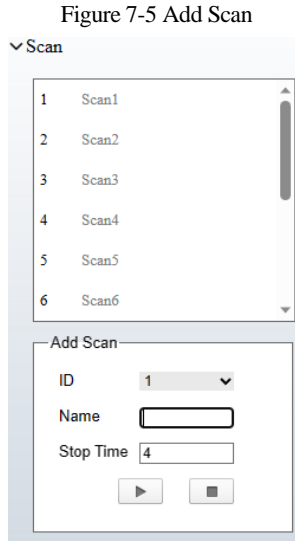

## Operation procedure

Step 1 Click Expand Arrow Down at Scan in the PTZ configuration area, the add Scan page is displayed, as shown in Figure 7-5.



Step 2 Select Scan ID (such as 1) from Add Scan box and enter the name of scan.

Step 3 Click , then use eight arrow keys in the **PTZ control** area to configure two positions, setup the stop time and then click  to complete adding a scan.

Step 4 Select the Scan from the Scan list and click  to apply the scan. If you want to delete the scan, move your mouse to the scan you want to delete, and click delete icon , the scan be deleted. The scan name not support to modify.

----End

## 7.2.5 Configure and Apply Tour





You can configure a tour to rotate the camera between presets set by PTZ.

### Operation procedure

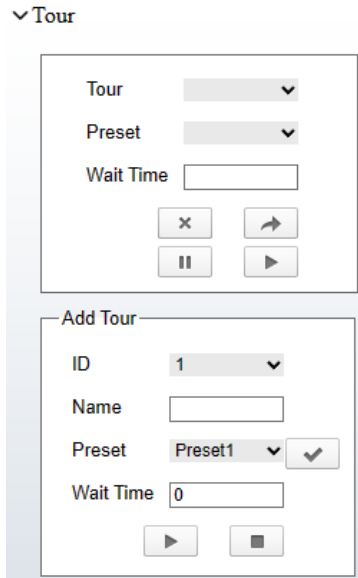
Step 1 Click Expand Arrow Down at Tour in the PTZ configuration area, the add tour page is displayed, as shown in Figure 7-6.

Figure 7-6 Add Tour



- Step 2 Select Tour ID (such as 2) from the Add Tour box, enter the tour name.
- Step 3 Select first required position preset from the **preset** drop-down list box.
- Step 4 Input the values from **Wait Time** area box to set the time to stay in this position preset.(0 sec~ 255 sec).
- Step 5 Click  button to begin setting tour.
- Step 6 Click  in the add tour page; select next position preset from the preset drop-down list box, and then input the values from Wait Time area box to set the time to stay in next position preset.(0 sec~ 255 sec).
- Step 7 Repeat former step until all required position presets are completed adding.
- Step 8 Click  to complete adding a tour (You also can click Cancel button to quit current setting).
- Step 9 Select a tour name and preset from the tour and preset drop-down list box, and then click  to apply the tour.

----End

## 7.2.6 Configure and Apply Bow Scan

You can configure an Bow Scan to apply preset. Scan, Track, or Tour regularly.

## Operation procedure

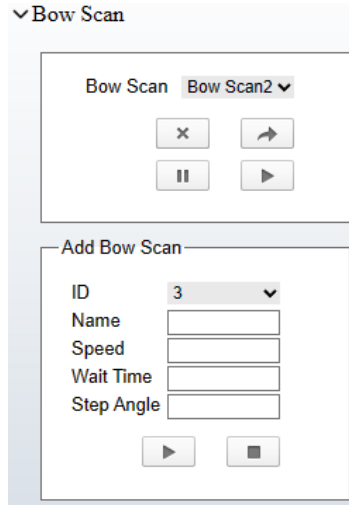

Step 1 Click Expand Arrow Down at Bow Scan in the PTZ configuration area, the Bow Scan page is displayed, as shown in Figure 7-7.

Figure 7-7 Bow Scan



Step 2 Select Scan ID (such as 1) from Add Bow Scan box and enter the name of scan.

Step 3 Enter the PTZ Speed, Wait Time, Step Angle.

Step 4 Click **icon**  to mark the start position, then use eight arrow keys in the **PTZ control** area to let the PTZ turn to the position you want, click **icon**  to complete adding the scan.

Step 5 Select the Scan from the Bow Scan list and click  to apply the scan. If you want to delete the scan.

----End

## 7.2.7 Configure and Apply Idle

You can configure an idle to apply preset. Scan, Track, or Tour regularly.

### Operation procedure

Step 1 Click Expand Arrow Down at Idle in the PTZ configuration area, the idle page is displayed, as shown in Figure 7-8.

Figure 7-8 Idle

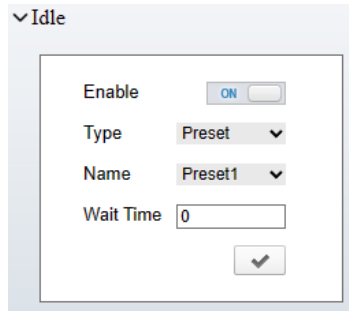

- Step 2 Click the Enable button to let the function going working first, select a monitor type from the **Type** drop-down list box. Monitor type can choose preset, Scan, track, tour.
- Step 3 Select a name form the **Name** drop-down list box, the name depends on what is your choose in type list.
- Step 4 Input a value from the **Wait Time** area box. Be careful the Time unit is minutes here.
- Step 5 Click button  to completed adding an idle. The PTZ camera will trigger the idle action if the PTZ without any operation.

----End

## 7.2.8 Configure Timer

### Operation procedure

- Step 1 Click Expand Arrow Down at Timer in the PTZ configuration area, the set timer page is displayed, as shown in Figure 7-9.

Figure 7-9 Set Timer

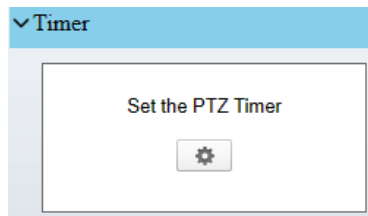

- Step 2 Click , the Timer page is displayed, as shown in Figure 7-10.

Figure 7-10 Timer

**Timer** [x]

Enable

Timer Mode: Once Time: 0-0-0

Timer	Begin Time	End Time	PTZ Type	Name	Clear
1	00:00	00:00	▼	▼	×
2	00:00	00:00	▼	▼	×
3	00:00	00:00	▼	▼	×

[✓]

- Step 3 Check **Enable** box.
- Step 4 Select the timer mode.
- Step 5 Select the required begin time at the **Begin Time** drop-down list box, and then select the required end time at the **End Time** drop-down list box.
- Step 6 Select the required monitor type at the PTZ type drop-down list box, you can select preset, Scan, Track, Tour, Cancel in the box, and then select a specific from the **Name** drop-down list box.(for example preset, 1).
- Step 7 Repeat Step 5 and Step 6 to add more required time.
- Step 8 Click  to complete timer setting.

----End

## 7.2.9 Configure Extension

You can use extension function including lamp, brush, defog, PTZ initialization, PTZ reset.

### Operation procedure

- Step 1 Click **Extension** tab page in the PTZ configuration interface, the extension page is displayed, as shown in Figure 7-11.



Figure 7-11 Extension

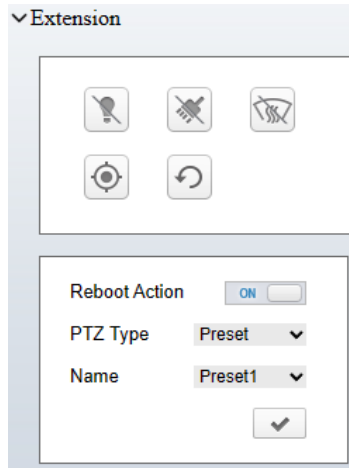

Step 2 Click  to enable the lamp.

Light On/Off is used to control the infrared camera shields on and off. It's available only to specific camera shields.

Step 3 Click  to enable the brush.

Brush is used to clean the lens. It's available only to a camera with a brush or a camera shield.

Step 4 Click  to enable the heater.

Heater is used to defog. It's available only to a camera with a heater.

Step 5 Click  to do a self-inspection.

Step 6 Click  to restore the PTZ to factory settings, the preset, track, scan, tour, and so on, all of these settings are restored immediately. Then the PTZ do a self-inspection.

----End

# 8 Intelligent Analysis

---

In visible light channel, at the **Configuration > Intelligent Analysis** interface, users can set the parameters of Intrusion, Single Line Crossing, Double Line Crossing, Multi-Loitering, Wrong-way and People Counting.

In thermal imaging channel, at the **Configuration > Intelligent Analysis** interface, users can set the parameters of Intrusion, Single Line Crossing, Double Line Crossing, Multi-Loitering, Wrong-way, People Counting, Enter Area and Leave Area.

There are some same functions for both channels, the following document will take the thermal imaging channel as an example for corresponding explanation.

## 8.1 Intrusion

The Intrusion function refers to that an alarm is generated when the targets of specified types (such as person, car, and both person and car) enter the deployment area.

### Procedure

- Step 1 Select **Intelligent Analysis > Intrusion** to access the **Intrusion** interface, as shown in Figure 8-1.

Figure 8-1 Intrusion Setting Interface

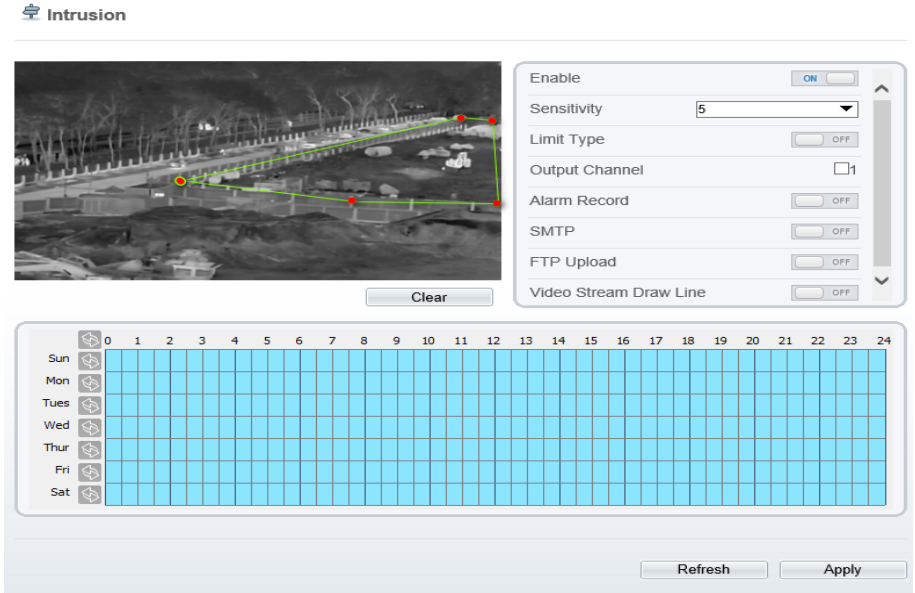

Step 2 Set all parameters for Intrusion. Table 8-1 describes the specific parameters.

Table 8-1 Parameter of Intrusion

Parameter	Description	Setting
Enable	Enable the button to enable the alarm.	[How to set] Click Enable to enable. [Default value] <b>OFF</b>
Sensitivity	The sensitivity of detecting the target, when the value is high, the target can be detected easily, but the accuracy will be lower.	[How to set] Choose from the drop-down list [Default value] <b>5</b>

Parameter	Description	Setting
Limit Target Type	Effective alarms are set based on target type, with options of Person or Car, person, car. When the device is used indoors, because of small space and large targets, alarms are triggered by person sometimes even if car is selected, leading to false alarms. It is recommended to set the target type as person for indoor use.	[How to set] Click to enable Limit Target Type. [Default value] <b>OFF</b>
Output Channel	If you check to set the Output Channel and the device is connected to an external alarm indicator, the alarm indicator signals when an alarm is triggered.	[How to set] Click to select an ID.
Alarm Record	Enable the button to enable the alarm record.	[How to set] Click to enable Alarm Record. [Default value] <b>OFF</b>
SMTP	Enable the button to enable SMTP sever. The parameters of SMTP can be set at <b>Configuration &gt; Network Service &gt; SMTP</b> interface.	[How to set] Click to enable SMTP. [Default value] <b>OFF</b>
FTP Upload	Enable the button to enable File Transfer Protocol. The parameters of FTP can be set at <b>Configuration &gt; Network Service &gt; FTP</b> interface.	[How to set] Click to enable FTP Upload. [Default value] <b>OFF</b>
Video Stream Draw Line	Enable, the deployment frame will show on the live video.	[How to set] Click to enable Video Stream Draw Line. [Default value] <b>OFF</b>

### Step 3 Set a deployment area

Move the cursor to the drawing interface and click to generate a point, move the cursor to draw a line, and then click to generate another point. This is how a line is generated. In this way, continue to draw lines to form any shape, and right-click to finish line drawing.

 **NOTE**

- A drawn line cannot cross another one, or the line drawing fails.
- Any shape with 8 sides at most can be drawn.
- The quantity of deployment areas is not limited yet and will be described in future when a limit is applied.

Step 4 Set deployment time

**Method 1:** Click left mouse button to select any time point within 0:00-24:00 from Monday to Sunday as shown in Figure 8-2.

**Method 2:** Hold down the left mouse button, drag and release mouse to select the deployment time within 0:00-24:00 from Monday to Sunday.

 **NOTE**

When you select time by dragging the cursor, the cursor cannot be moved out of the time area. Otherwise, no time can be selected.

**Method 3:** Click  in the deployment time page to select the whole day or whole week.

**Deleting deployment time:** Click  again or inverse selection to delete the selected deployment time.

Figure 8-2 Deployment Time Setting Interface



----End

## 8.2 Single Line Crossing

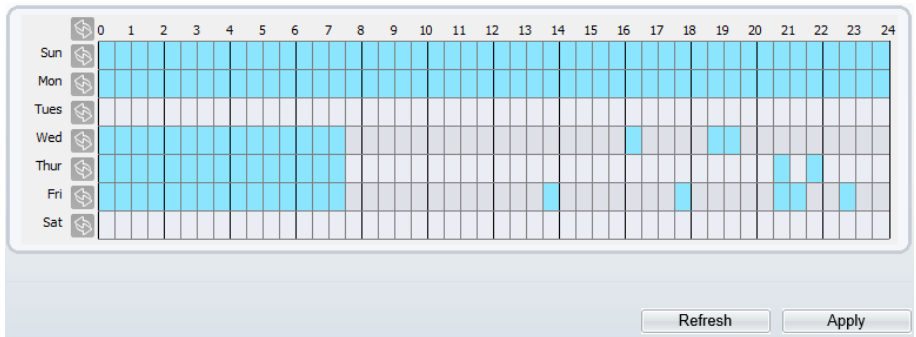
A single line crossing is a line that is set at a concerned position within the monitored field of view and specifies the forbidden travel direction, an alarm is generated when the targets of specified types (such as person or car) cross this line.

## Procedure

Step 1 Select **Intelligent Analysis > Single Line Crossing** to access the **Single Line Crossing** setting interface, as shown in Figure 8-3.

Figure 8-3 Single Line Crossing Setting Interface

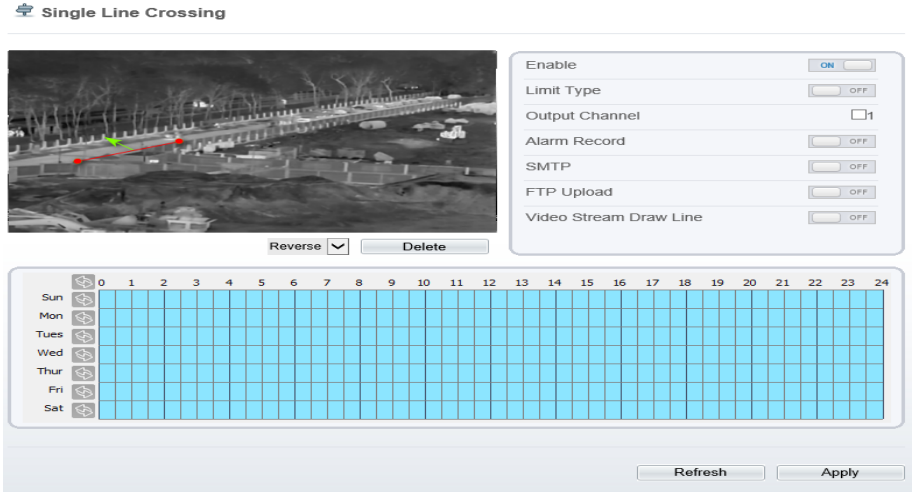

Step 2 Set all parameters for the single line crossing. Table 8-2 describes the specific parameters.

Table 8-2 Parameters of Single Line Crossing

Parameter	Description	Setting
Enable	Enable the button to enable the alarm.	[How to set] Click Enable to enable . [Default value] OFF
Limit Target Type	Effective alarms are set based on target type, with options of Person or Car, person, car. When the device is used indoors, because of small space and large targets, alarms are triggered by person sometimes even if car is selected, leading to false alarms. It is recommended to set the target type as person for indoor use.	[How to set] Click to enable Limit Target Type. [Default value] OFF
Output Channel	If you check to set the Output Channel and the device is connected to an external alarm indicator, the alarm indicator signals when an alarm is triggered.	[How to set] Click to select an ID.

Parameter	Description	Setting
Alarm Record	Enable the button to enable the alarm record.	[How to set] Click to enable Alarm Record. [Default value] <b>OFF</b>
SMTP	Enable the button to enable SMTP sever. The parameters of SMTP can be set at <b>Configuration &gt; Network Service &gt; SMTP</b> interface.	[How to set] Click to enable SMTP. [Default value] <b>OFF</b>
FTP Upload	Enable the button to enable File Transfer Protocol. The parameters of FTP can be set at <b>Configuration &gt; Network Service &gt; FTP</b> interface.	[How to set] Click to enable FTP. [Default value] <b>OFF</b>
Video Stream Draw Line	Enable, the deployment frame will show on the live video.	[How to set] Click to enable Video Stream Draw Line. [Default value] <b>OFF</b>

### Step 3 Set a deployment area

**Drawing a line:** move the cursor to the drawing interface, hold down the left mouse button, and move the cursor to draw a line. When you release the left mouse button, a Single Line Crossing is generated.

**Setting a single line crossing:** click a line (and the trip line turns red) to select the Single Line Crossing and set its direction as **positive**, **reverse** or **bidirectional**, or **delete the selected** line. You can also press and hold left mouse button at the endpoint of a Single Line Crossing and move the mouse to modify the position and length of this single virtual fence. You can right-click to delete the single virtual fence.

## NOTE

- A single line crossing is not within any deployment area, therefore, when an alarm is generated, the trace always exists. Only when the target object moves out of the field of view, the trace disappears.
- Try to draw the single line crossing in the middle, because the recognition of a target takes time after target appearance on the screen and an alarm is generated only when the object is recognized to have crossed the single virtual fence.
- The single line crossing which detects person foot as the recognition target cannot be too short, because a short single line crossing tends to miss targets.

Step 4 Set deployment time.

For more details please refer to *8.1 Step 4*.

----End

## 8.3 Double Line Crossing

Double Line Crossing refer to two lines that are set at a concerned special position within the field of view and specify the forbidden travel direction. When the targets of specified types (such as person or car) move along the set travel direction and cross these lines in a certain order (line 1 followed by line 2) in pass max time, an alarm is generated.

Procedure

Step 1 Select **Intelligent Analysis > Double Line Crossing** to access the **Double Line Crossing** setting interface, as shown in Figure 8-4.

Figure 8-4 Double Line Crossing Setting Interface

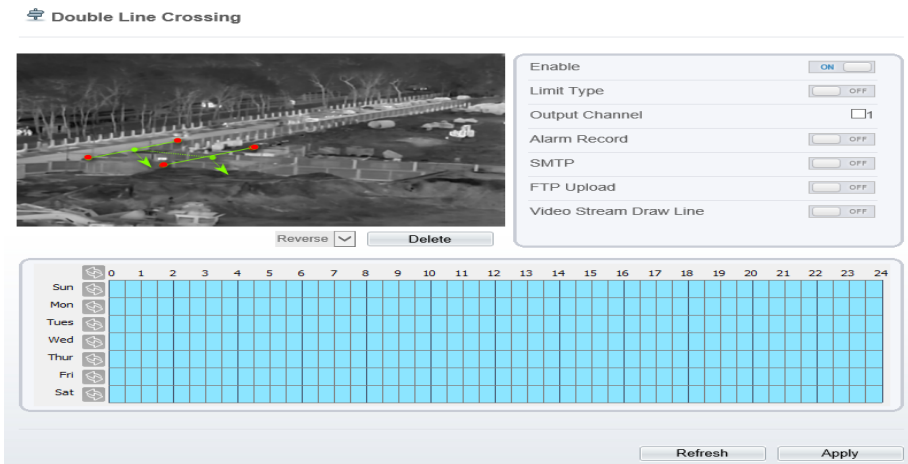

Step 2 Set all parameters for the double line crossing. Table 8-3 describes the specific parameters.



Table 8-3 Parameters of Double Line Crossing

Parameter	Description	Setting
Enable	Enable the button to enable the alarm.	[How to set] Click to enable. [Default value] <b>OFF</b>
Limit Target Type	Effective alarms are set based on target type, with options of Person or Car, person, car. When the device is used indoors, because of small space and large targets, alarms are triggered by person sometimes even if car is selected, leading to false alarms. It is recommended to set the target type as person for indoor use.	[How to set] Click to enable Limit Target Type. [Default value] <b>OFF</b>
Output Channel	If you check to set the Output Channel and the device is connected to an external alarm indicator, the alarm indicator signals when an alarm is triggered.	[How to set] Click to select an ID.
Alarm Record	Enable the button to enable the alarm record.	[How to set] Click to enable Alarm Record. [Default value] <b>OFF</b>
SMTP	Enable the button to enable SMTP sever. The parameters of SMTP can be set at <b>Configuration &gt; Network Service &gt; SMTP</b> interface.	[How to set] Click to enable SMTP. [Default value] <b>OFF</b>
FTP Upload	Enable the button to enable File Transfer Protocol. The parameters of FTP can be set at <b>Configuration &gt; Network Service &gt; FTP</b> interface.	[How to set] Click to enable FTP. [Default value] <b>OFF</b>

Parameter	Description	Setting
Video Stream Draw Line	Enable, the deployment frame will show on the live video.	[How to set] Click to enable Video Stream Draw Line. [Default value] <b>OFF</b>

### Step 3 Set a deployment area

**Drawing a line:** Move the cursor to the drawing interface, hold down the left mouse button, and move the cursor to draw two lines. When you release the left mouse button, two numbered virtual fences are generated. Choose either of the double line crossing to set the direction to Positive or Reverse.

**Setting double line crossing:** Click one of the double line crossing (and the virtual fence turns red) to select this virtual fence and set the direction to **Positive** or **Reverse**, or delete the selected line. You can also press and hold left mouse button at the endpoint of a virtual fence and move the mouse to modify the position and length of this virtual fence. You can right-click to delete the double line crossing.



#### NOTE

- The double line crossing are in sequential order. An alarm is generated only when a target crosses virtual fence 1 and then virtual fence 2 within the set maximum passing time.
- The double line crossing are not within any deployment area, therefore, when an alarm is generated, the trace always exists. Only when the target object moves out of the field of view, the trace disappears.
- Try to draw double line crossing in the middle, because the recognition of a target takes time after target appearance on the screen and an alarm is generated only when the object is recognized to have crossed the double virtual fences.
- The double line crossing which detect person foot as the recognition target cannot be too short, because short Double Line Crossing tend to miss targets.

### Step 4 Set deployment time.

For more details please refer to *8.1 Step 4*.

----End

## 8.4 Multi-Loitering

Multi-loitering allows setting the shortest loitering time for multiple targets of specified type (such as person or car) within the deployment area in the field of view. When the loitering time of the multiple targets within this area meets the set shortest loitering time, an alarm is generated.

## Procedure

Step 1 Select **Intelligent Analysis > Multi-Loitering** to access the **Multi-Loitering** setting interface, as shown in Figure 8-5.

Figure 8-5 Multi-Loitering Setting Interface

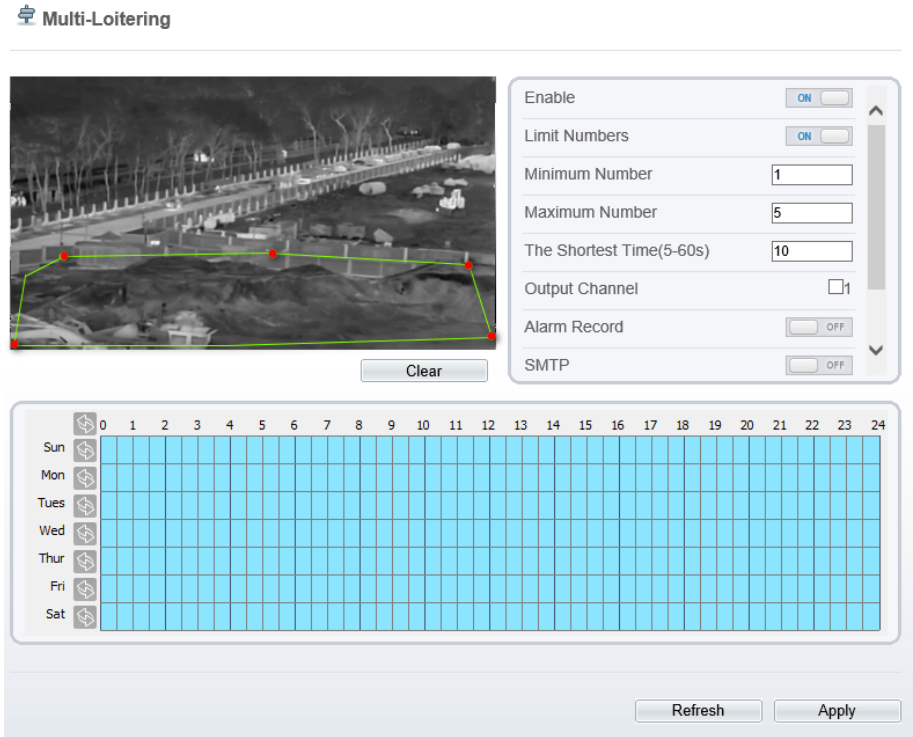

Step 2 Set all parameters for multiple loitering. Table 8-4 describes the specific parameters.

Table 8-4 Parameters of Multi-Loitering

Parameter	Description	Setting
Enable	Enable the button to enable the alarm.	[How to set] Click Enable to enable. [Default value] <b>OFF</b>

Parameter	Description	Setting
Limit Target Size	The target size for triggering an effective alarm is set based on the actual target size. The minimum size is 1000 square centimeters and the maximum size is 100000 square centimeters. When setting the target size, you need to well set “Real size in scene” in advanced parameters, otherwise no alarms may be generated.	[How to set] Click to enable Limit Target Size. [Default configuration] <b>OFF</b>
Limit Numbers	When Limit Numbers is set to OFF, an alarm is generated no matter how many people loiter. When Limit Numbers is set to ON, if the minimum number is set to 2 and the maximum number is set to 3, an alarm is generated for 2-3 people loitering. Other settings are the same as loitering.	[How to set] Click to enable Limit Numbers.
The Shortest Time (Sec)	The time that the target person wanders in the area must not be less than the minimum time. Settable range: 5-60s	[How to set] Input a value in the area box. [Default value] 10s
Output Channel	If you check to set the Output Channel and the device is connected to an external alarm indicator, the alarm indicator signals when an alarm is triggered.	[How to set] Click to select an ID.
Alarm Record	Enable the button to enable the alarm record.	[How to set] Click to enable Alarm Record. [Default value] <b>OFF</b>
SMTP	Enable the button to enable SMTP sever. The parameters of SMTP can be set at <b>Configuration &gt; Network Service &gt; SMTP</b> interface.	[How to set] Click to enable SMTP. [Default value] <b>OFF</b>

Parameter	Description	Setting
FTP Upload	Enable the button to enable File Transfer Protocol. The parameters of FTP can be set at <b>Configuration &gt; Network Service &gt; FTP</b> interface.	[How to set] Click to enable FTP Upload. [Default value] <b>OFF</b>
Video Stream Draw Line	Enable, the deployment frame will show on the live video.	[How to set] Click to enable Video Stream Draw Line. [Default value] <b>OFF</b>

### Step 3 Set a deployment area.

Move the cursor to the drawing interface and click to generate a point, move the cursor to draw a line, and then click to generate another point. This is how a line is generated. In this way, continue to draw lines to form any shape, and right-click to finish line drawing.



#### NOTE

- A drawn line cannot cross another one, or the line drawing fails.
- Any shape with 8 sides at most can be drawn .
- The quantity of deployment areas is not limited yet and will be described in future when a limit is applied.

### Step 4 Set deployment time

Details please refer to *8.1 Step 4*

----**End**

## 8.5 Wrong-way

Wrong-way allows setting the travel direction criteria for a target within an area on the video screen. When a target of specified type (such as people or car) within this area moves in the set travel direction, an alarm is generated.

### Procedure

Step 1 Select **Intelligent Analysis > Wrong-way** to access the **Wrong-way** setting interface, as shown in Figure 8-6.

Figure 8-6 Wrong-way Setting Interface

Wrong-way

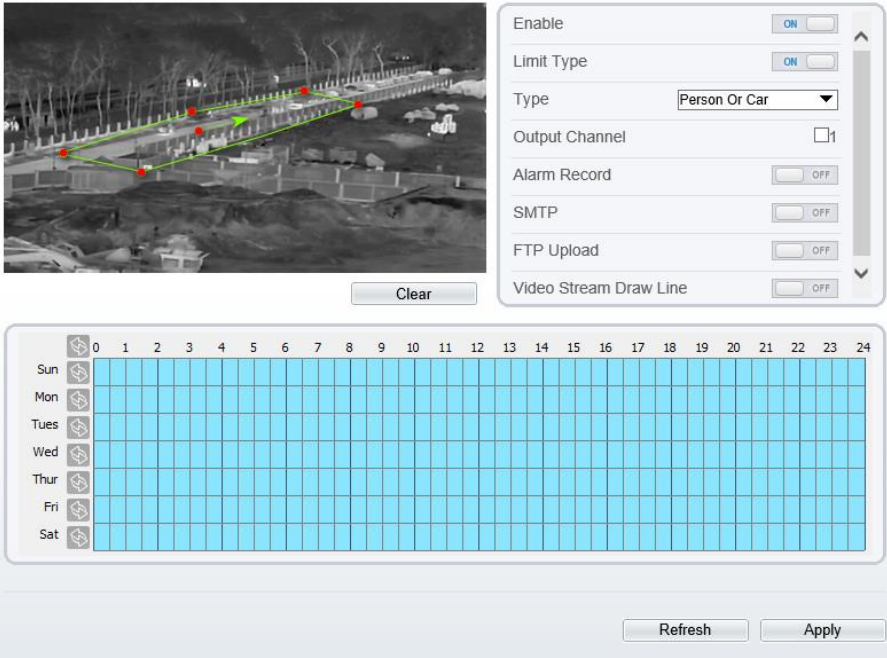

Step 2 Set all parameters for Wrong-way. Table 8-5 describes the specific parameters.

Table 8-5 Parameter of Wrong-way

Parameter	Description	Setting
Enable	Enable the button to enable the alarm.	[How to set] Click Enable to enable. [Default value] OFF

Parameter	Description	Setting
Limit Target Type	Effective alarms are set based on target type, with options of Person or Car, person, car. When the device is used indoors, because of small space and large targets, alarms are triggered by person sometimes even if car is selected, leading to false alarms. It is recommended to set the target type to person for indoor use.	[How to set] Click to enable Limit Target Type. [Default value] <b>OFF</b>
Output Channel	If you check to set the Output Channel and the device is connected to an external alarm indicator, the alarm indicator signals when an alarm is triggered.	[How to set] Click to select an ID.
Alarm Record	Enable the button to enable the alarm record.	[How to set] Click to enable Alarm Record. [Default value] <b>OFF</b>
SMTP	Enable the button to enable SMTP sever. The parameters of SMTP can be set at <b>Configuration &gt; Network Service &gt; SMTP</b> interface.	[How to set] Click to enable SMTP. [Default value] <b>OFF</b>
FTP Upload	Enable the button to enable File Transfer Protocol. The parameters of FTP can be set at <b>Configuration &gt; Network Service &gt; FTP</b> interface.	[How to set] Click to enable FTP Upload. [Default value] <b>OFF</b>
Video Stream Draw Line	Enable, the deployment frame will show on the live video.	[How to set] Click to enable Video Stream Draw Line. [Default value] <b>OFF</b>

### Step 3 Set a deployment area

Move the cursor to the drawing interface and click to generate a point, move the cursor to draw a line, and then click to generate another point. This is how a line is generated. In this way, continue to draw lines to form any shape, and right-click to finish line drawing, move the arrow in the field can set the direction of wrong-way.

## NOTE

- A drawn line cannot cross another one, or the line drawing fails.
- Any shape with 8 sides at most can be drawn .
- The quantity of deployment areas is not limited yet and will be described in future when a limit is applied.

### Step 4 Set deployment time

Details please refer to *8.1 Step 4*.

----End

## 8.6 People Counting

Draw a line in the designated area to count, you can count the number of people passing through the area, set the corresponding alarm linkage.

Procedure

- Step 1 Select **Intelligent Analysis > People Counting** to access the **People Counting** setting interface, as shown in Figure 8-7.

Figure 8-7 People Counting

 People Counting

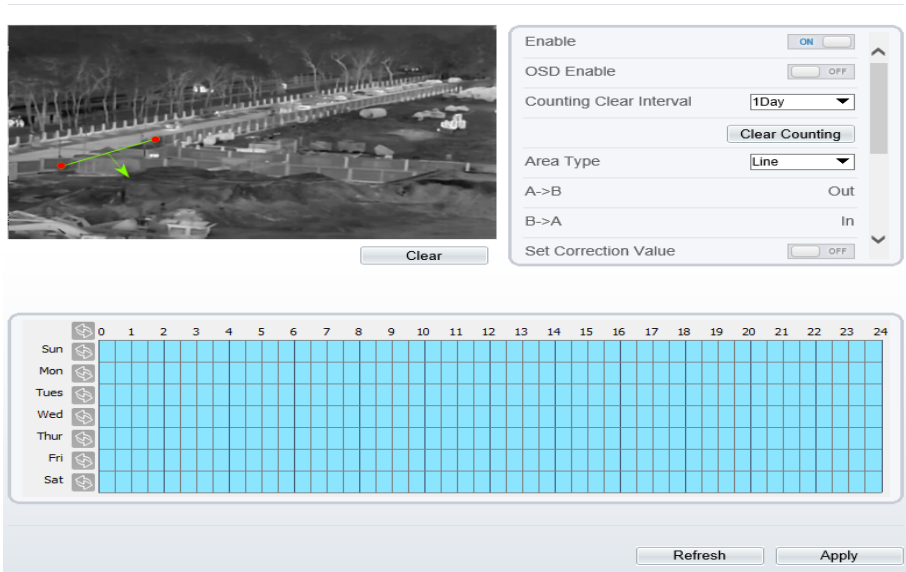

Enable  ON

OSD Enable  OFF

Counting Clear Interval 1Day

Area Type Line

A->B Out

B->A In

Set Correction Value  OFF

	0	1	2	3	4	5	6	7	8	9	10	11	12	13	14	15	16	17	18	19	20	21	22	23	24
Sun																									
Mon																									
Tues																									
Wed																									
Thur																									
Fri																									
Sat																									



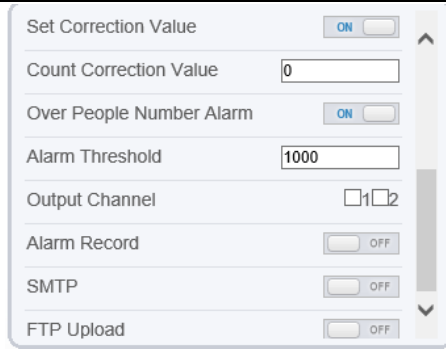

Step 2 Set all parameters for **People Counting**. Table 8-6 describes the specific parameters.

Table 8-6 Parameters of People Counting

Parameter	Description	Setting
Enable	Enable the button to enable the alarm.	[How to set] Click Enable to enable. [Default value] <b>OFF</b>
OSD Enable	Enable the OSD, the count data will show on live video screen.	[How to set] Click Enable to enable. [Default value] <b>OFF</b>
Counting Clear Interval	The camera will clear counting data at the setting interval. Click the “Clear Counting”, clearing the data immediately.	[How to set] Choose from drop-down list. [Default value] <b>12 hours</b>
Area Type	Draw a line on live video screen. The label of A and B indicate out and in.	[How to set] Choose from drop-down list. [Default value] <b>Line</b>
Set Correction Value	Enable, set the count correction value, it can be positive or negative. For example, if there are 30 people enter the area before counting, input 30 to correct. If 30 people go out the area, input -30.	[How to set] Enable /Input a value in the area box. [Default value] <b>0</b>

Parameter	Description	Setting
Over People Number Alarm	Enable, When the counting number reaches the threshold value, an alarm is triggered.	[How to set] Click Enable to enable. [Default value] <b>OFF</b>
Alarm Threshold	There is an alarm when the number reaches or exceeds this value.	[How to set] Enable /Input a value in the area box. [Default value] <b>1000</b>
Output Channel	If you check to set the Output Channel and the device is connected to an external alarm indicator, the alarm indicator signals when an alarm is triggered.	[How to set] Click to select an ID.
Alarm Record	Enable the button to enable the alarm record.	[How to set] Click to enable Alarm Record. [Default value] <b>OFF</b>
SMTP	Enable the button to enable SMTP sever. The parameters of SMTP can be set at <b>Configuration &gt; Network Service &gt; SMTP</b> interface.	[How to set] Click to enable SMTP. [Default value] <b>OFF</b>
FTP Upload	Enable the button to enable File Transfer Protocol. The parameters of FTP can be set at <b>Configuration &gt; Network Service &gt; FTP</b> interface.	[How to set] Click to enable FTP Upload. [Default value] <b>OFF</b>

### Step 3 Set a deployment area

Move the cursor to the drawing interface and click to generate a point, move the cursor to draw a line, and then click to generate another point. This is how a line is generated. In this way, continue to draw lines to form any shape, and right-click to finish line drawing.

### Step 4 Set deployment time

For more details please refer to *8.1 Step 4*.

**----End**

## 8.7 Enter Area

Set the area, when the targets enter the area, it will alarm.

### Procedure

- Step 1 Select **Intelligent Analysis > Enter Area** to access the **Enter Area** setting interface, as shown in Figure 8-8.

Figure 8-8 Enter Area

#### Enter Area

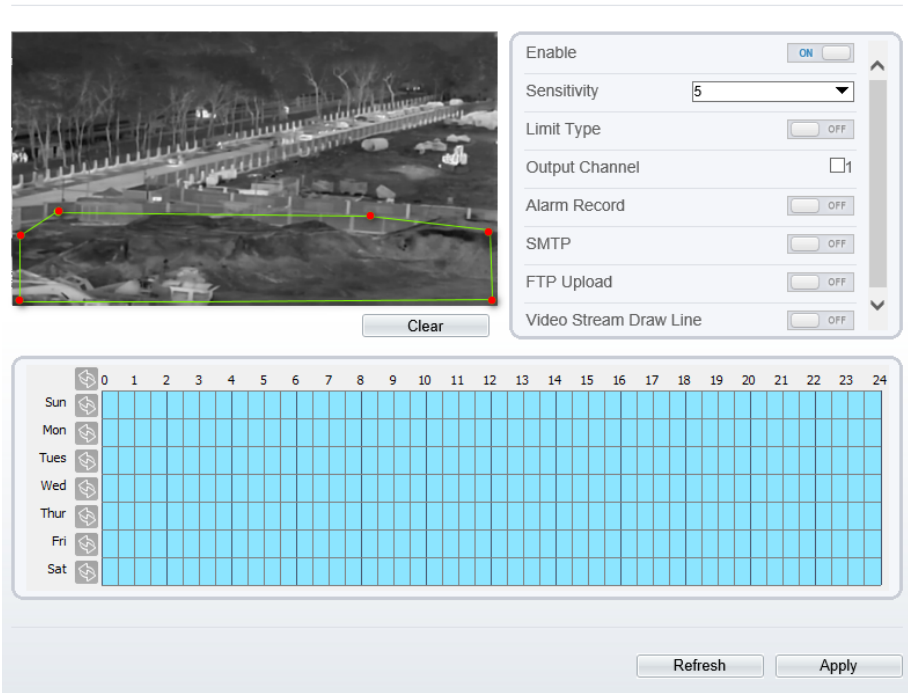

- Step 2 Set all parameters for illegal parking. Table 8-7 describes the specific parameters.

Table 8-7 Description of Parameters for Enter Area

Parameter	Description	Setting
Enable	Enable the button to enable the enter area alarm.	[How to set] Click Enable to enable. [Default value] <b>OFF</b>

Parameter	Description	Setting
Sensitivity	The sensitivity of detecting the target, when the value is high, the target can be detected easily, but the accuracy will be lower.	[How to set] Choose from the drop-down list [Default value] <b>5</b>
Limit Target Type	Effective alarms are set based on target type, with options of Person or Car, person, car. When the device is used indoors, because of small space and large targets, alarms are triggered by person sometimes even if car is selected, leading to false alarms. It is recommended to set the target type to person for indoor use.	[How to set] Click to enable Limit Target Type. [Default value] <b>OFF</b>
Output Channel	If you check to set the Output Channel and the device is connected to an external alarm indicator, the alarm indicator signals when an alarm is triggered.	[How to set] Click to select an ID.
Alarm Record	Enable the button to enable the alarm record.	[How to set] Click to enable Alarm Record. [Default value] <b>OFF</b>
SMTP	Enable the button to enable SMTP sever. The parameters of SMTP can be set at <b>Configuration &gt; Network Service &gt; SMTP</b> interface.	[How to set] Click to enable SMTP. [Default value] <b>OFF</b>
FTP Upload	Enable the button to enable File Transfer Protocol. The parameters of FTP can be set at <b>Configuration &gt; Network Service &gt; FTP</b> interface.	[How to set] Click to enable FTP Upload. [Default value] <b>OFF</b>
Video Stream Draw Line	Enable, the deployment frame will show on the live video.	[How to set] Click to enable Video Stream Draw Line. [Default value] <b>OFF</b>

Step 3 Set a deployment area

Move the cursor to the drawing interface and click to generate a point, move the cursor to draw a line, and then click to generate another point. This is how a line is generated. In this way, continue to draw lines to form any shape, and right-click to finish line drawing.

Step 4 Set deployment time

For more details please refer to 8.1 Step 4.

----End

## 8.8 Leave Area

When the targets leave the setting area, it will be alarm.

### Procedure

Step 1 Select **Intelligent Analysis > Leave Area** to access the **Leave Area** setting interface, as shown in Figure 8-9.

Figure 8-9 Leave Area

#### Leave Area

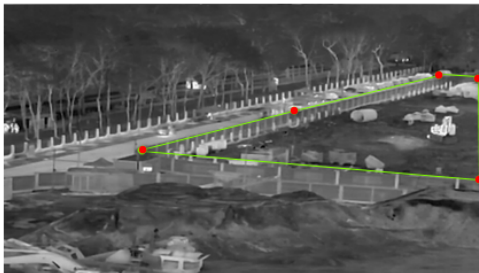

Clear

Enable	<input checked="" type="checkbox"/>
Sensitivity	5
Limit Type	<input type="checkbox"/>
Output Channel	<input type="checkbox"/> 1
Alarm Record	<input type="checkbox"/>
SMTP	<input type="checkbox"/>
FTP Upload	<input type="checkbox"/>
Video Stream Draw Line	<input type="checkbox"/>

	0	1	2	3	4	5	6	7	8	9	10	11	12	13	14	15	16	17	18	19	20	21	22	23	24
Sun	<input checked="" type="checkbox"/>	<input checked="" type="checkbox"/>	<input checked="" type="checkbox"/>	<input checked="" type="checkbox"/>	<input checked="" type="checkbox"/>	<input checked="" type="checkbox"/>	<input checked="" type="checkbox"/>	<input checked="" type="checkbox"/>	<input checked="" type="checkbox"/>	<input checked="" type="checkbox"/>	<input checked="" type="checkbox"/>	<input checked="" type="checkbox"/>	<input checked="" type="checkbox"/>	<input checked="" type="checkbox"/>	<input checked="" type="checkbox"/>	<input checked="" type="checkbox"/>	<input checked="" type="checkbox"/>	<input checked="" type="checkbox"/>	<input checked="" type="checkbox"/>	<input checked="" type="checkbox"/>	<input checked="" type="checkbox"/>	<input checked="" type="checkbox"/>	<input checked="" type="checkbox"/>	<input checked="" type="checkbox"/>	<input checked="" type="checkbox"/>
Mon	<input checked="" type="checkbox"/>	<input checked="" type="checkbox"/>	<input checked="" type="checkbox"/>	<input checked="" type="checkbox"/>	<input checked="" type="checkbox"/>	<input checked="" type="checkbox"/>	<input checked="" type="checkbox"/>	<input checked="" type="checkbox"/>	<input checked="" type="checkbox"/>	<input checked="" type="checkbox"/>	<input checked="" type="checkbox"/>	<input checked="" type="checkbox"/>	<input checked="" type="checkbox"/>	<input checked="" type="checkbox"/>	<input checked="" type="checkbox"/>	<input checked="" type="checkbox"/>	<input checked="" type="checkbox"/>	<input checked="" type="checkbox"/>	<input checked="" type="checkbox"/>	<input checked="" type="checkbox"/>	<input checked="" type="checkbox"/>	<input checked="" type="checkbox"/>	<input checked="" type="checkbox"/>	<input checked="" type="checkbox"/>	<input checked="" type="checkbox"/>
Tues	<input checked="" type="checkbox"/>	<input checked="" type="checkbox"/>	<input checked="" type="checkbox"/>	<input checked="" type="checkbox"/>	<input checked="" type="checkbox"/>	<input checked="" type="checkbox"/>	<input checked="" type="checkbox"/>	<input checked="" type="checkbox"/>	<input checked="" type="checkbox"/>	<input checked="" type="checkbox"/>	<input checked="" type="checkbox"/>	<input checked="" type="checkbox"/>	<input checked="" type="checkbox"/>	<input checked="" type="checkbox"/>	<input checked="" type="checkbox"/>	<input checked="" type="checkbox"/>	<input checked="" type="checkbox"/>	<input checked="" type="checkbox"/>	<input checked="" type="checkbox"/>	<input checked="" type="checkbox"/>	<input checked="" type="checkbox"/>	<input checked="" type="checkbox"/>	<input checked="" type="checkbox"/>	<input checked="" type="checkbox"/>	<input checked="" type="checkbox"/>
Wed	<input checked="" type="checkbox"/>	<input checked="" type="checkbox"/>	<input checked="" type="checkbox"/>	<input checked="" type="checkbox"/>	<input checked="" type="checkbox"/>	<input checked="" type="checkbox"/>	<input checked="" type="checkbox"/>	<input checked="" type="checkbox"/>	<input checked="" type="checkbox"/>	<input checked="" type="checkbox"/>	<input checked="" type="checkbox"/>	<input checked="" type="checkbox"/>	<input checked="" type="checkbox"/>	<input checked="" type="checkbox"/>	<input checked="" type="checkbox"/>	<input checked="" type="checkbox"/>	<input checked="" type="checkbox"/>	<input checked="" type="checkbox"/>	<input checked="" type="checkbox"/>	<input checked="" type="checkbox"/>	<input checked="" type="checkbox"/>	<input checked="" type="checkbox"/>	<input checked="" type="checkbox"/>	<input checked="" type="checkbox"/>	<input checked="" type="checkbox"/>
Thur	<input checked="" type="checkbox"/>	<input checked="" type="checkbox"/>	<input checked="" type="checkbox"/>	<input checked="" type="checkbox"/>	<input checked="" type="checkbox"/>	<input checked="" type="checkbox"/>	<input checked="" type="checkbox"/>	<input checked="" type="checkbox"/>	<input checked="" type="checkbox"/>	<input checked="" type="checkbox"/>	<input checked="" type="checkbox"/>	<input checked="" type="checkbox"/>	<input checked="" type="checkbox"/>	<input checked="" type="checkbox"/>	<input checked="" type="checkbox"/>	<input checked="" type="checkbox"/>	<input checked="" type="checkbox"/>	<input checked="" type="checkbox"/>	<input checked="" type="checkbox"/>	<input checked="" type="checkbox"/>	<input checked="" type="checkbox"/>	<input checked="" type="checkbox"/>	<input checked="" type="checkbox"/>	<input checked="" type="checkbox"/>	<input checked="" type="checkbox"/>
Fri	<input checked="" type="checkbox"/>	<input checked="" type="checkbox"/>	<input checked="" type="checkbox"/>	<input checked="" type="checkbox"/>	<input checked="" type="checkbox"/>	<input checked="" type="checkbox"/>	<input checked="" type="checkbox"/>	<input checked="" type="checkbox"/>	<input checked="" type="checkbox"/>	<input checked="" type="checkbox"/>	<input checked="" type="checkbox"/>	<input checked="" type="checkbox"/>	<input checked="" type="checkbox"/>	<input checked="" type="checkbox"/>	<input checked="" type="checkbox"/>	<input checked="" type="checkbox"/>	<input checked="" type="checkbox"/>	<input checked="" type="checkbox"/>	<input checked="" type="checkbox"/>	<input checked="" type="checkbox"/>	<input checked="" type="checkbox"/>	<input checked="" type="checkbox"/>	<input checked="" type="checkbox"/>	<input checked="" type="checkbox"/>	<input checked="" type="checkbox"/>
Sat	<input checked="" type="checkbox"/>	<input checked="" type="checkbox"/>	<input checked="" type="checkbox"/>	<input checked="" type="checkbox"/>	<input checked="" type="checkbox"/>	<input checked="" type="checkbox"/>	<input checked="" type="checkbox"/>	<input checked="" type="checkbox"/>	<input checked="" type="checkbox"/>	<input checked="" type="checkbox"/>	<input checked="" type="checkbox"/>	<input checked="" type="checkbox"/>	<input checked="" type="checkbox"/>	<input checked="" type="checkbox"/>	<input checked="" type="checkbox"/>	<input checked="" type="checkbox"/>	<input checked="" type="checkbox"/>	<input checked="" type="checkbox"/>	<input checked="" type="checkbox"/>	<input checked="" type="checkbox"/>	<input checked="" type="checkbox"/>	<input checked="" type="checkbox"/>	<input checked="" type="checkbox"/>	<input checked="" type="checkbox"/>	<input checked="" type="checkbox"/>

Refresh

Apply

Step 2 Set all parameters for illegal parking. Table 8-8 describes the specific parameters.

Table 8-8 Parameters of Leave Area

Parameter	Description	Setting
Enable	Enable the button to enable the leave area alarm.	[How to set] Click Enable to enable. [Default value] <b>OFF</b>
Sensitivity	The sensitivity of detecting the target, when the value is high, the target can be detected easily, but the accuracy will be lower.	[How to set] Choose from the drop-down list [Default value] <b>5</b>
Limit Target Type	Effective alarms are set based on target type, with options of Person or Car, person, car. When the device is used indoors, because of small space and large targets, alarms are triggered by person sometimes even if car is selected, leading to false alarms. It is recommended to set the target type to person for indoor use.	[How to set] Click to enable Limit Target Type. [Default value] <b>OFF</b>
Output Channel	If you check to set the Output Channel and the device is connected to an external alarm indicator, the alarm indicator signals when an alarm is triggered.	[How to set] Click to select an ID.
Alarm Record	Enable the button to enable the alarm record.	[How to set] Click to enable Alarm Record. [Default value] <b>OFF</b>
SMTP	Enable the button to enable SMTP sever. The parameters of SMTP can be set at <b>Configuration &gt; Network Service &gt; SMTP</b> interface.	[How to set] Click to enable SMTP. [Default value] <b>OFF</b>
FTP Upload	Enable the button to enable File Transfer Protocol. The parameters of FTP can be set at <b>Configuration &gt; Network Service &gt; FTP</b> interface.	[How to set] Click to enable FTP Upload. [Default value] <b>OFF</b>

Parameter	Description	Setting
Video Stream Draw Line	Enable, the deployment frame will show on the live video.	[How to set] Click to enable Video Stream Draw Line. [Default value] <b>OFF</b>

**Step 3** Set a deployment area

Move the cursor to the drawing interface and click to generate a point, move the cursor to draw a line, and then click to generate another point. This is how a line is generated. In this way, continue to draw lines to form any shape, and right-click to finish line drawing.

**Step 4** Set deployment time.

Details please refer to *8.1 Step 4*.

**----End**

# 9 AI Multiobject of Thermal Channel

## 9.1 Parameters of AI Multiobject

To enable full body detection and vehicle detection, when the device detects the object, it will be triggered alarm.

Figure 9-1 AI Multiobject

### AI Multiobject

The screenshot displays the AI Multiobject configuration interface. On the left is a thermal camera feed showing a construction site. Below the feed is a 'Clear' button. To the right is a settings panel with the following options:

- Fullbody Detection:  ON
- Vehicle Detection:  ON
- Confidence Coefficient: Mid (dropdown menu)
- Static Target Filter:  OFF
- Algorithms Library Version: v1.0.0\_20221109

Below the settings panel is a calendar grid for scheduling. The grid has columns for hours (0-24) and rows for days of the week (Sun, Mon, Tues, Wed, Thur, Fri, Sat). Each cell in the grid contains a small icon representing a camera. At the bottom of the interface are 'Refresh' and 'Apply' buttons.

Table 9-1 Parameters of AI Multiobject

Parameter	Description	How to set
Full body Detection	The camera will snap the whole body when someone appears in live video.	Enable



Parameter	Description	How to set
Vehicle Detection	The camera will snap the vehicle when the vehicles appears in live video.	Enable
Confidence Coefficient	The range of detecting object, there are three type, such as high, mid and low. The higher confidence, the better the detecting quality.	Choose from drop-down list.
Static Target Filter	If the target is static, the device will filter this target. For example, if a car stop for long time, the device will be filtered.	Enable

Schedule: Drag the mouse to select the time to enable alarming, or click  to choose all day or all week to enable alarming.

Figure 9-2 Schedule



----End

# 10 AI Multiobject of Visible Channel

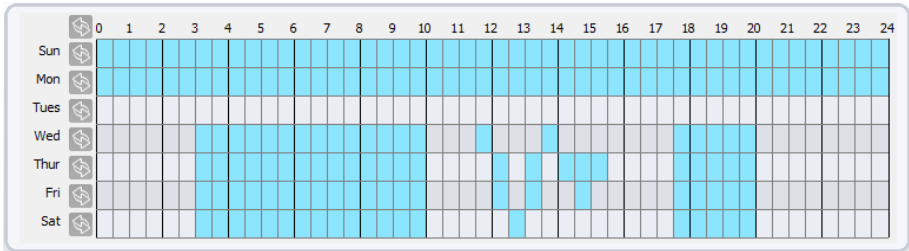
## 10.1 AI Configuration

Choose **Configuration > AI Multiobject** to set parameter of detected face, and vehicle plate.

Figure 10-1 AI Multiobject interface

### AI Multiobject

The interface displays the following configuration options:

- Face Detection:  ON
- Fullbody Detection:  ON
- Vehicle Detection:  OFF
- Box Display Mode: OFF
- Detection Area:  OFF
- Confidence Coefficient: Mid
- Face Pixel Min(30-300): 64
- Body Pixel Min(30-300): 50

The calendar grid below shows a 7-day week (Sun to Sat) and a 24-hour day (0 to 24). All cells in the grid are currently empty, indicating no scheduled events.

Buttons at the bottom: Refresh, Apply

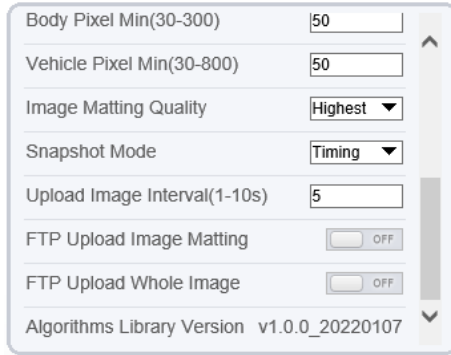



Table 1-1 lists the AI multiobject parameters.

Table 1-1 AI multiobject parameters

Parameter	Description	How to set
Face Detection	The camera will snap the face when someone appears in live video.	Enable
Fullbody Detection	The camera will snap the whole body when someone appears in live video.	Enable
Vehicle Detection	The camera will snap the vehicle when the vehicle appears in live video.	Enable
Box Display Mode	Choose one to a trace box will show at live video. There three mode can be chosen.  Mode 1:   Mode 2: 	Choose from drop list.
Detection Area	Enable to show the detection area on live video.	
Confidence Coefficient	The range of snap image, there are three types, such as high, mid and low. The higher the confidence, the better the snap quality and the fewer snapshots.	Choose from drop list.
Face Pixel Min (30-300)	30-300 pixels, the smaller the pixel be set, the more face will be captured, but it may be mistaken.	Input a value ranges 30 to 300
Body Pixel Min (30-300)	30-300 pixels, the smaller the pixel be set, the more body will be captured, but it may be mistaken.	Input a value range 30 to 300

Parameter	Description	How to set
Vehicle Pixel Min (30-300)	30-300 pixels, the smaller the pixel be set, the more face will be captured, but it may be mistaken.	Input a value ranges 30 to 300
Image Matting Quality	The quality of snap image, There are three mode can be chosen, such as low, mid and high.	Choose from drop list.
Snapshot Mode	There are three mode can be chosen, such as timing, and optimal.	Choose from drop list.
Upload Image Interval (1-10 s)	At timing mode, set the interval of upload image.	Input a value ranges 1 to 10
FTP Upload Image Matting	<b>Configuration &gt; Network Service &gt; FTP</b> , set FTP related parameters, the captured picture will be sent to the set FTP location	Enable
FTP Upload Whole Image	Capture a picture and send a whole image.	Enable

# A Troubleshooting

Common Trouble	Possible Cause	Solution
Unable to access the web	Network is not connected.	<ul style="list-style-type: none"><li>• Connect the network cable of the camera to the PC to check whether the network cable is in good contact.</li><li>• Run the ping command to check the network connection and whether the device works normally.</li></ul>
	IP address is occupied.	Directly connect the camera to the PC, and reset the IP address of the camera.
	The IP addresses of the PC and the device are in different networks.	Check the IP address, subnet mask and gateway setting of the camera.
PTZ or high speed dome is out of control.	The protocol, bit-rate, or address setting of the PTZ is incorrect.	Modify the address of the PTZ on the web.
	The signal cable is unconnected or not connected correctly.	Check the signal strength, and reconnect the signal cable.
The measured temperature is not accurate.	The device is just powered on, and the temperature of the cavity is unstable.	The temperature of the cavity is stable within 15 to 30 min after the device is powered on.
	The FFC mode is incorrect.	The FFC mode is auto by default. If the mode is set to manual, it will be no block calibration, which may lead to fuzzy pictures and inaccurate temperature.
	The target configuration is incorrect.	Check whether the emission rate and distance of the target are configured correctly.

Common Trouble	Possible Cause	Solution
An error occurs in accessing the web of the device after the upgrade.	The data in the cache of browser is not updated in time.	Delete the cache of the Internet Explorer. The steps are as follows (taking IE9 as an example): <ol style="list-style-type: none"> <li>1. Open the Internet Explorer.</li> <li>2. Select <b>Tools &gt; Internet Options</b>.</li> <li>3. On the <b>General</b> tab, select <b>Delete</b> under <b>Browsing history</b>. The <b>Delete Browsing History</b> dialog box appears.</li> <li>4. Select all check boxes.</li> <li>5. Click <b>Delete</b>.</li> </ol> <p>Relogin the web page of the camera.</p>
Upgrade failed.	No network cable is connected.	Ensure the upgrade network is connected.
	The network setting is incorrect.	Check whether the network setting is correct.
	The upgrade package is incorrect.	Perform the correct upgrade package again.
No self-test no image output	There is a broken line in the circuit	Find breakpoints, rewiring.
	Low supply voltage	Replace the power adapter to increase the output voltage.
Self-test exception	Low supply voltage	Replace the power adapter to increase the output voltage.
Equipment control is normal, image instability (Analog video)	Poor video circuit contact	Troubleshooting, rewiring
	Access device exception	Replacement access device
Equipment control is normal, image instability (Web video)	Network line bad contact	Dismantling bad point, re-wiring.
	Access to computer performance is insufficient, take up CPU usage	Lower stream and resolution

Common Trouble	Possible Cause	Solution
	Lack of network bandwidth	Replacement of industrial Gigabit switches
	Access decoder performance decoder	Replacement of high-performance
Self-test normal, cannot control	Wrong wiring	Rewiring
	Set the baud rate, protocol, address and device mismatch	Screen configuration according to device parameters
Repeated restart	Insufficient supply voltage or voltage instability	To ensure that the input device voltage stability
Cannot control the lens to perform zoom and Focus action	Wiring error	Re-connect the lens control line
	Circuit board lens control problems	Replacement circuit board (please contact after-sales rework processing, do not replace parts or repair)
Cannot recall the set lens preset point	DIP switch relative to the set lens preset dialing is not set to ON	DIP switch control lens preset dialing dial into ON
The image is lost when the control device rotates	Rotation process at the same location lost image	Conductive slip ring there is a bad contact, replace the parts (please contact after-sales rework, do not replace parts or repair)

# B Common Emission Rate

## Emission Rate

The emission rate is the capability of an object to emit or absorb energy. An ideal transmitter provides an emission rate of emitting 100% of intake energy. An object with an emission rate of 0.8 can absorb 80% of intake energy, and reflect the remaining 20%. The emission rate is the ratio of the energy emitted by an object at a specific temperature to that emitted by an ideal radiator at the same temperature. The range of emission rate value is 0.0 to 1.0 generally.

Materials	Temperature (°C/°F)	Emissivity
Gold (High-purity)	227/440	0.02
Aluminum foil	27/81	0.04
Aluminum sheet	27/81	0.18
Aluminum used for families (flat)	23/73	0.01
Aluminum plate ( 98.3% purity)	227/440	0.04
	577/1070	0.06
Aluminum plate (rough)	26/78	0.06
Aluminum (oxidized @ 599°C)	19 /390	0.11
	599/1110	0.19
Polished aluminum	38/100	0.22
Tin (light tinned Iron sheet)	25/77	0.04
Nickel wire	187/368	0.1



Lead (99.9% purity, No oxidized)	127/260	0.06
Copper	199/390	0.18
Cobalt	599/1110	0.19
Steel	199/390	0.52
	599/1110	0.57
Tinned iron sheet (Light)	28/82	0.23
Brass(High-polish)	247/476	0.03
Brass (Tough rolled, polished metal wire)	21/70	0.04
Tinned Iron (Light)	-	0.13
Iron plate (Rust eaten)	20/68	0.69
Rolled steel sheet	21/71	0.66
Ferric oxide	100/212	0.74
Wrought-iron	21/70	0.94
Fused iron	1299-1399/2370-2550	0.29
Copper (Polished)	21-117/70-242	0.02
Copper(Polished, not reflected)	22/72	0.07
Copper (Heavy oxide Board )	25/77	0.78
Enamel (Fuse on iron)	19/66	0.9
Formica Plate	27/81	0.94
Frozen soil	-	0.93

Brick (Red, rough)	21/70	0.93
Brick (Unglazed, rough)	1000/1832	0.8
Carbon (T - carbon 0.9% ash)	127/260	0.81
Concrete	-	0.94
Glass (Glossy)	22/72	0.94
Granite (Surfaced)	21/70	0.85
Ice	0/32	0.97
Marble (I Polished, grey)	22/72	0.93
Asbestos board	23/74	0.96
Asbestos paper	38/100	0.93
	371/700	0.95
Asphalt ( Paving the road)	4/39	0.97
Paper ( Black tar)	-	0.93
Paper (White)	-	0.95
Plastic (White)	-	0.91